



CS 999

QUICK / SMART STOP



Technical and User Manual

07/ 2004

CS 999

QUICK / SMART STOP

TECHNICAL DATA / DIAGRAM PROGRAM	1
DIMENSIONS CS 999 + QUICK SMART STOP	2
FITTING THE AUTOMATIC MEASURING STOP	3
SETTING UP THE MOULDING GUIDE	4
CONNECTING THE AUTOMATIC MEASURING STOP	4
USING THE 999 QUICK/SMART STOP :	
- THE TOUCH SCREEN	5
- SMART STOP: REBATE BOTTOM THICKNESS MEASURER	6
- CREATING / MODIFYING / DELETING A FILE	7
EXECUTING A FILE	8
STANDARD SIZES	9
MENU MAINTENANCE PARAMETERS	9
SPARE PARTS LISTS & DRAWINGS	10

TECHNICAL DATA

Dimensions: length 2390 mm / width 512 m / height 1130 mm

Power supply(distributed from the saw 999): 380 V / 220 V Triphasé 50/60 Hz

Automatic stop measuring function: See diagram below.

Thickness measurement without rebate: Max. moulding thickness check 80 mm inter.

Options: Length measurement greater than 1800 mm on request / Bar code scanning/ PC connection.

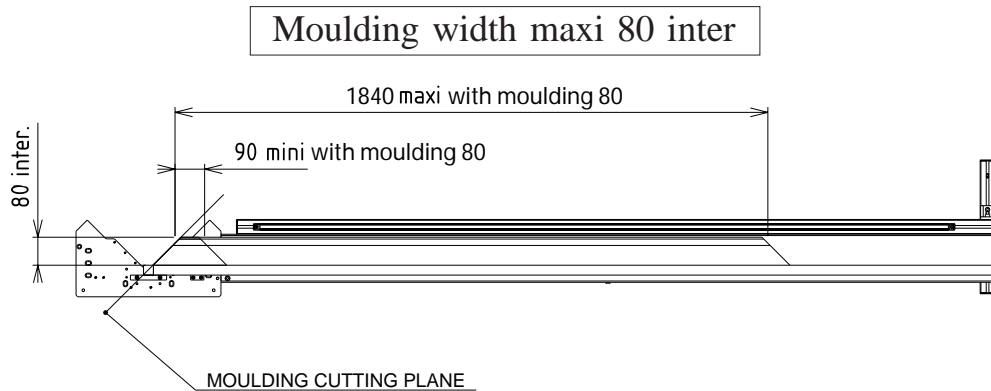
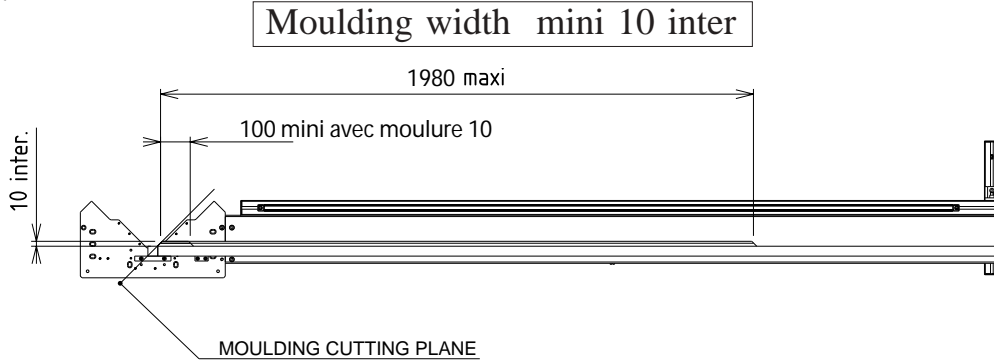

PROGRAM OF QUICK / SMART STOP CS 999

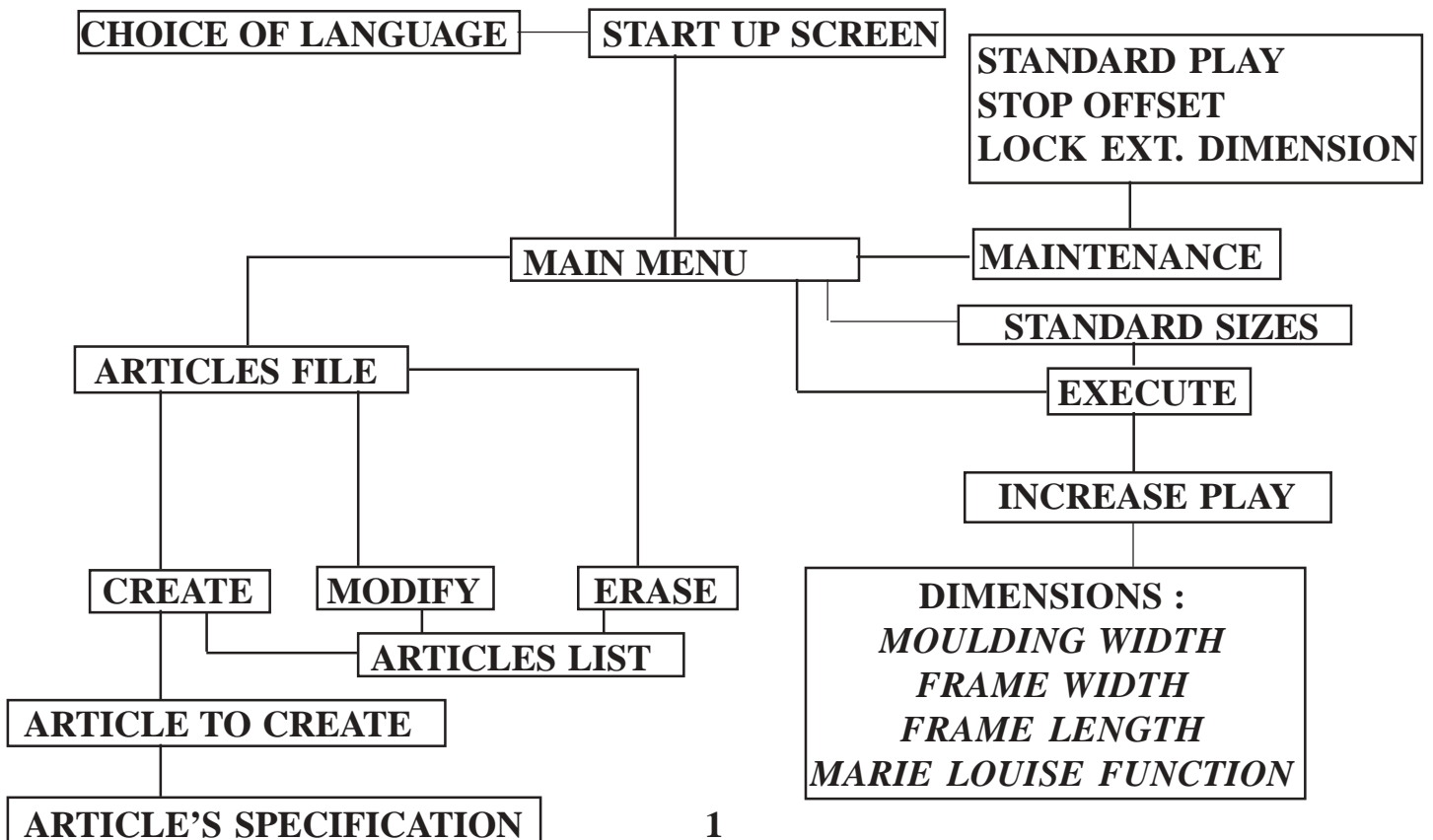

DIMENSIONS CS 999 + QUICK SMART STOP

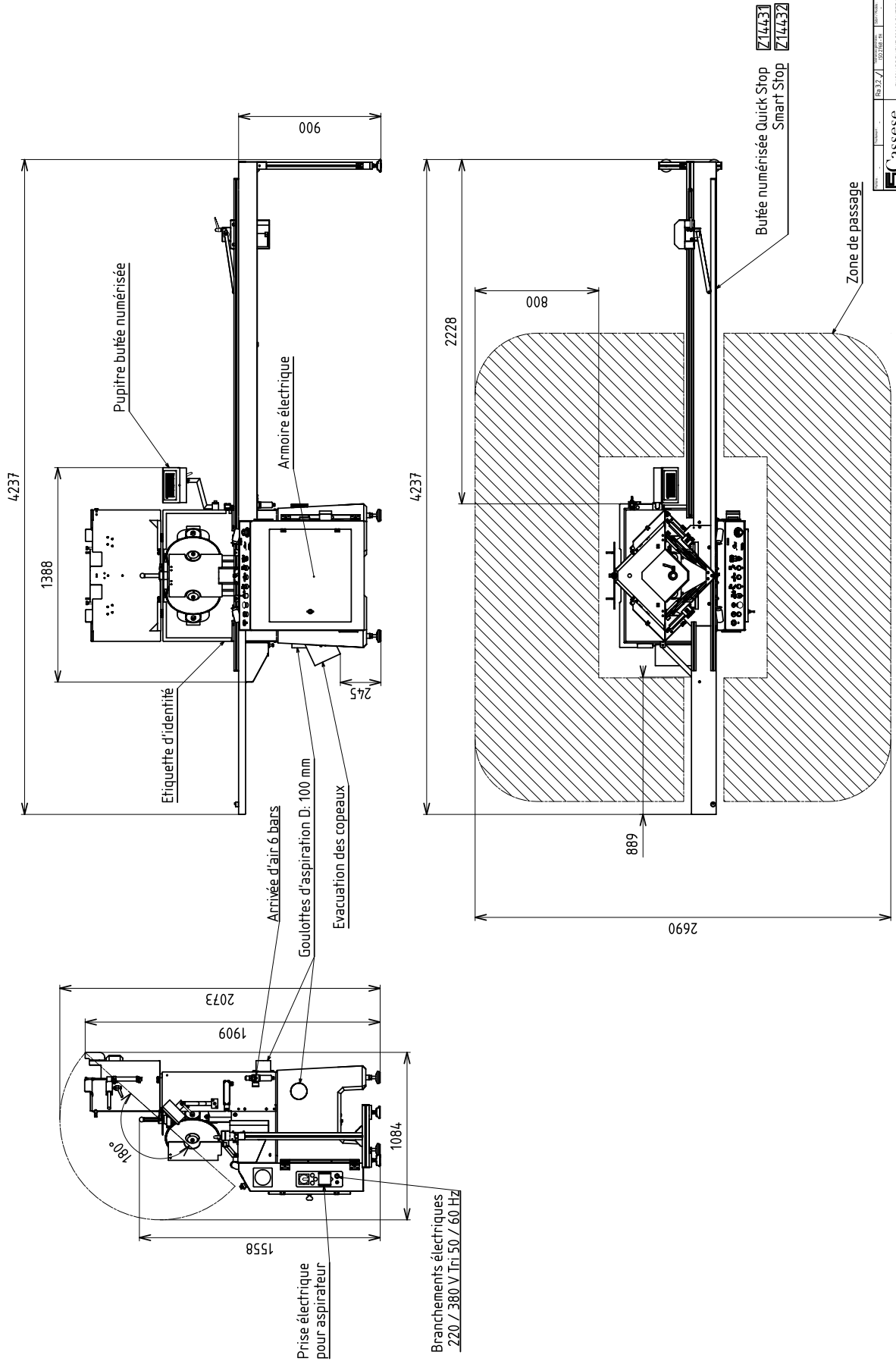

ENDIMPRENT CS999 BUTEE NUMERISEE

 Z14431 Z14432

 01

FITTING THE AUTOMATIC MEASURING STOP

The automatic measuring stop can only be fitted once the CS 999 has been made level with the ground.

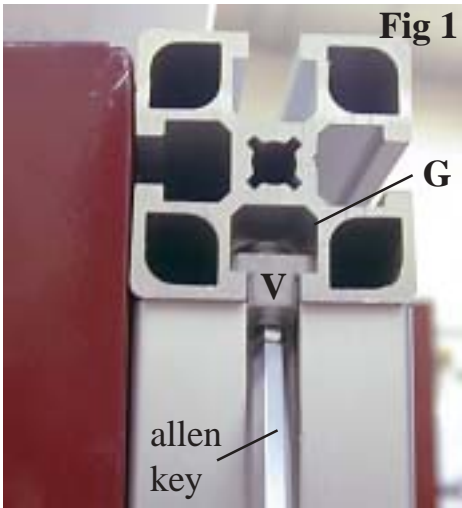

Fig 1

Remove the screw V that is underneath and at the end of the automatic stop (Fig.2). Fix the support foot at the end of the automatic stop, by sliding its male part V into the rail G (Fig 1). Tighten V with an Allen key #4mm.

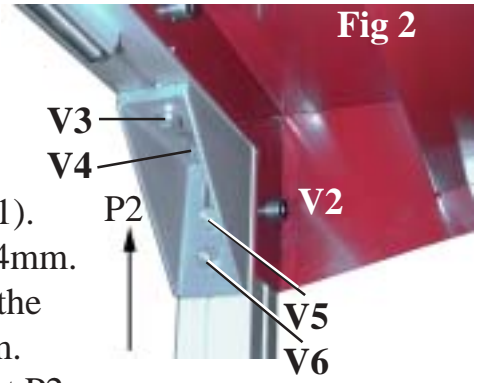

Fig 2

Now, (see Fig.2) fix and tighten the screw V2 with an Allen key 6mm. Now, bring the square attachment P2 up to underneath of Automatic stop after having removed its 2 screws V3 and V4, then tighten it with these two same screws and tighten the screws V5 and V6 (with an Allen key 5mm).

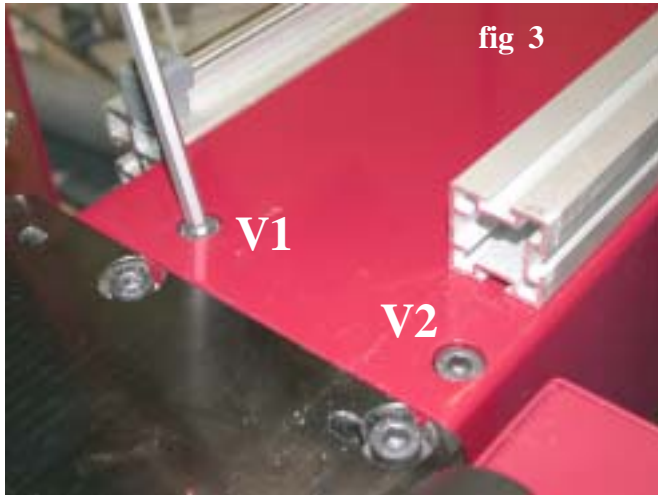

fig 3

Next bring the numeric stop against the right-hand table and secure it with screws V1 and V2 (6-mm Allen key).

Using a 19-mm open-end spanner adjust the levels of the numeric stop with respect to the table of the CS 999 by screwing nut EH of feet P1 and P2 (Fig. 4) in or out.

Turn the base of the feet so that the points for fastening to the floor are accessible for drilling into the floor (Fig. 5).



fig 5

fig 4

Check the levels with a ruler (Fig. 6)

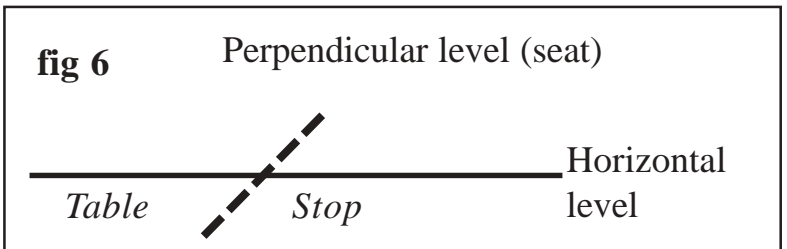

After fitting and adjustment: secure each of the 2 feet to the floor so that the adjustments are maintained if the foot of the numeric stop receives a blow.



SETTING UP THE MOULDING GUIDE

Using a 10-mm open-end spanner loosen the 8 nuts below the numeric stop and screws **VB** and **VA** at the left-hand end of the numeric stop.

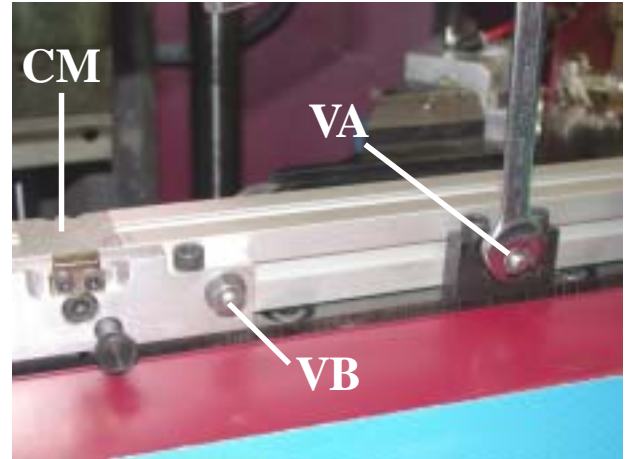
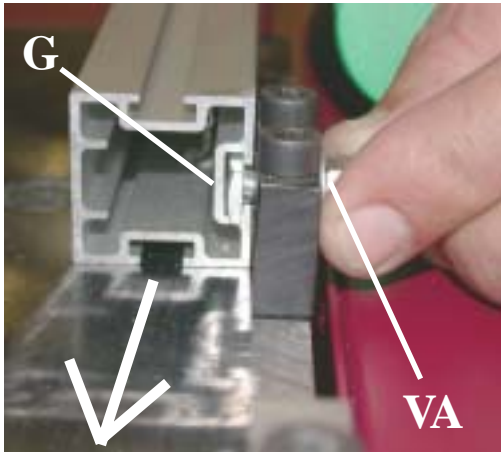

Slide the moulding guide towards the cutting table and against the martyr cube, at the same time inserting screws **VA** and **VB** into the trough **G** of the moulding guide. Tighten nuts **VA** and **VB** using the 10-mm open-end spanner.

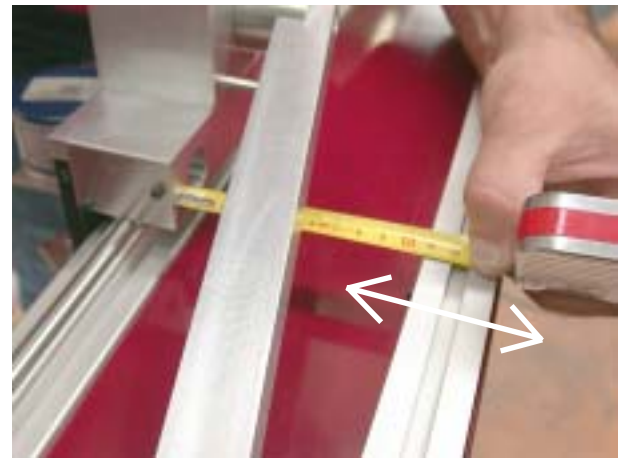

Carry out adjustment of the moulding guide by sliding the stop manually as close to the cutting table as possible. Using a metre ruler measure the distance shown in Figure 5. Next bring the stop level with the first locking screw on the moulding guide. Slide the moulding guide sideways until the distance at this point is the same as that measured in Figure 5, then tighten the nut from below (10-mm open-end spanner).



CONNECTING THE NUMERIC STOP

Connect the 3 connectors (located below the main isolating switch **SG**) as follows:

- **GREEN** cable to the **left-hand** connector
- **BLACK** cable to the **middle** connector
- **GREY** cable to the **right-hand** connector.

USING THE 999 QUICK/SMART STOP

The operation of the stop has almost no effect on saw operation.

The only signals exchanged are:

- Disabling stop movement if the blades are moving forward.
- Rebate bottom measurement pushbutton (Smart Stop).
- Rebate bottom measurement coder value (Smart Stop).

The 999 Quick Stop/Smart Stop can store 800 files comprising:

- An 8-digit reference.
- Moulding rebate bottom thickness (accuracy: 1/10th mm).
- Frame width (accuracy 1/10th mm).
- Frame length (accuracy 1/10th mm).
- Dimension position: Internal or external.

Nota: En fonction de la forme et des défauts de la moulure, la précision de largeur sera de $\pm 0,5$.

The 999 Quick Stop/Smart Stop can also store 80 standard frames identified only by their length and width dimensions.

Using the touch screen

The 999 Quick Stop/Smart Stop is equipped with an intuitive touch screen for man/machine dialogue. The operating principle is the same as for the other machines in the range (4095/3099/2095).

The screen only displays the information required and the keys represent the only possible choices. This makes it much simpler to use as the user is guided.

When the numeric keypad appears, any values changed must be validated: .

If the terminal detects a problem, the corresponding message is displayed until the problem is remedied (e.g. "STOP OFF" etc.).

At start-up, the "initialisation" screen appears (programme version, screen version, number of cuts, distance travelled and choice of available languages).



When the screen is touched, the main menu appears.

SMART STOP: REBATE BOTTOM THICKNESS MEASURER

Switch the machine on by setting the main switch to ON. (see page 4)

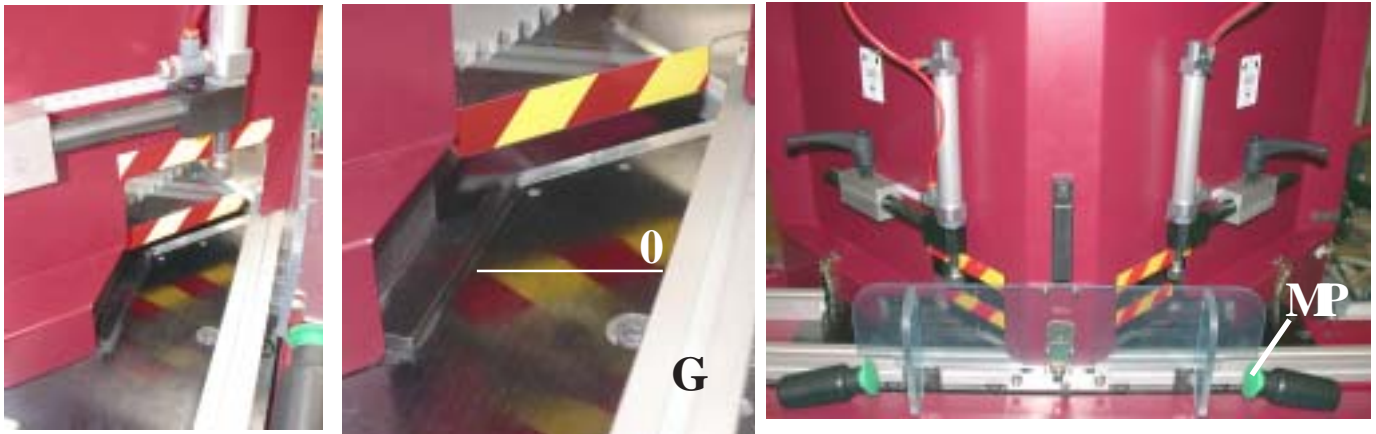

If you are using the SMART STOP, the following warning message appears if the **measurer button** (MP) is pressed:



-> In this case, you will need to remove any moulding and let the measurer position itself against the fixed rule G. Now, still keeping the measurer button pressed down, touch the RESET MEASURER screen key.

-> If you make a mistake (e.g. a moulding was still in place!), you can start the procedure again via the MAINTENANCE menu (see page10).

Once the measurer origin is set, put the moulding on the table in front of the left hand vertical presser and against the moulding guide (rebate towards blades). The execute screen will appear when the measurer button is touched:

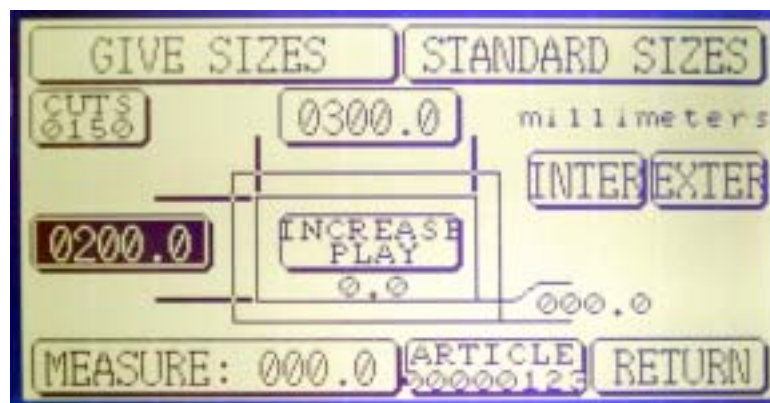

The moulding measurement will be displayed in the MEASUREMENT key (032.1 for example). The measurement is validated by touching the MEASUREMENT key and it will be used to compute the required position, if we work with internal size. With external size, the moulding width doesn't affect the stop position.

CREATING / MODIFYING / DELETING A FILE

Starting from the main menu, press the FILES menu. The files sub-menu appears.



- Create
- Modify
- Erase
- Free memory: xxx/800

All the submenus of CREATE/MODIFY/DELETE contain a FILE LIST key which will provide a list of files already saved.

Touch CREATE, then type the reference of your file (8 digits max.) using the numeric key pad.

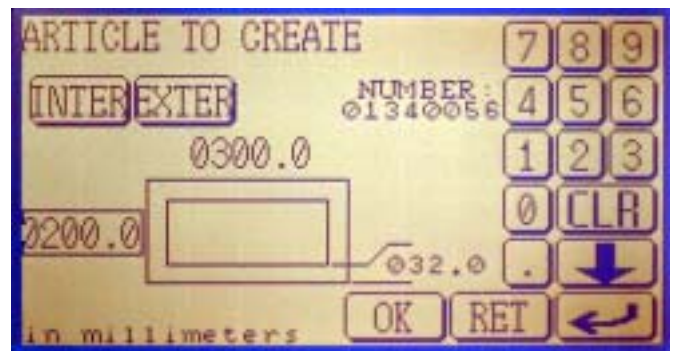
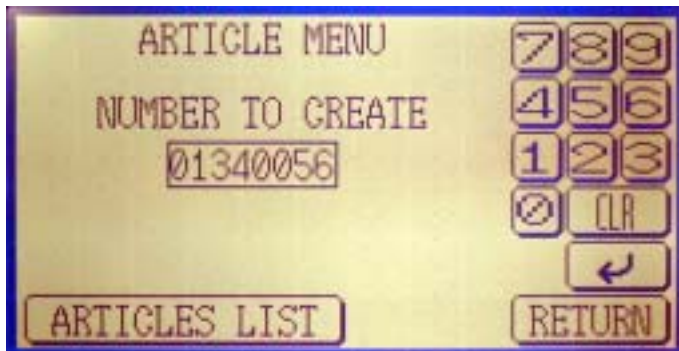

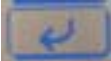
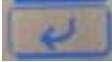
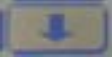
Touch the validation key . The message 'PLEASE WAIT' appears for about 1/2 second then the file data screen appears. You can modify any of the values using the numeric keypad. All the values entered must be validated immediately by touching the  key. Use the key  to move from one value to another.

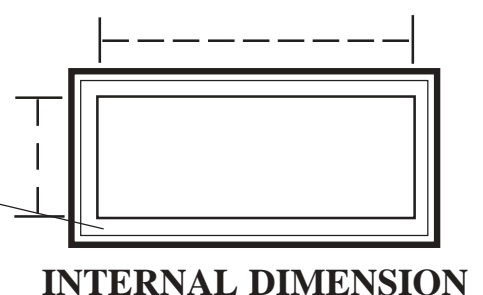
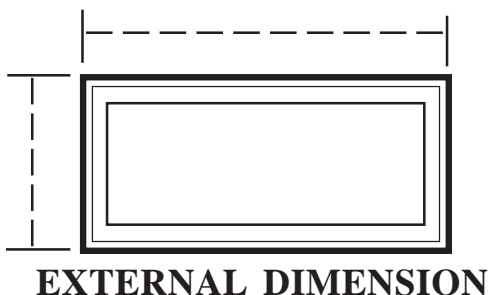

Once the values have been entered, you can use the OK key to validate the file or choose not to validate it and return to the file menu using the RET key.

Likewise, from the file menu screen, you can modify an existing file, delete a file or view the file list. The files are not necessarily arranged in chronological entry order. A deleted file is in fact a file with values set to 0000 (this programme function is also found on models CS4095 / CS2095).

EXECUTING A FILE

In the main menu, touch EXECUTE.

If the stop is not yet initialised, it will return to its origin point (stop offset). This will be the one and only time that automatic initialisation occurs after switching on; after this the position is set automatically. The first execution screen is then displayed.

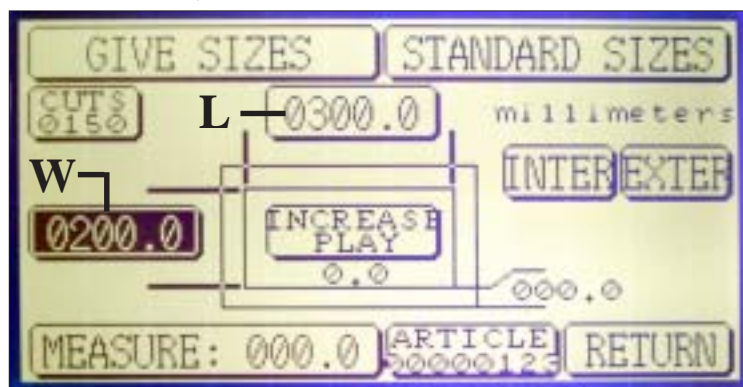

The file parameters displayed in this screen are the last parameters created, modified, listed or executed. This means that after a machine power failure, you do not need to re-enter a reference before resuming work. Also, you can list the file that you are interested in and then execute it without having to call up its reference.

You can call up a reference for execution via the FILE key. You can modify the execution parameters by touching GIVE SIZES or STD SIZES.

This does not alter the saved parameters, but only those that are executed. In every case:

The dimension depends on the moulding thickness and the dimension position: Internal or External.

- If the dimension is INTERNAL, the standard play (allowance) is automatically added (see how to set this play in Parameters section, page 9). The play for the cut to be made can be modified by pressing the ADD PLAY key on the screen.
- The minimum and maximum measure capacities depend on the moulding thickness and the dimension position (internal / external).
- Use the dimension keys that are shown next to the length (L) and width (W) of the frame to switch from short to long dimension.
- Use INTER. / EXTER. to switch your choice between internal (rebate) and external (outside of frame) measures (unless the external dimension is locked – see Parameters section page 10)).
- The dimensions are computed for 45° (version for 999). The numeric stops QUICK or SMART coming with a 999 MA (multi-angled) need to be informed of the cutting angle of the saw ; press the 45°-key on screen to change it to 30° (6-sided frames) or 22.5° (8-sided frames).

Note : the angle changes on the 999 MA saw and on the numeric stop are independent from each other.

- The machine features a cut counter which is incremented each time the blades START a cut. To reset to 0000, touch the CUT key. This does not reset the general counter to 00000000 (displayed on the first screen at start-up).

- If STOP OFF is pressed (red rotating-locking «mushroom» button) the stop returns to its point of origin after unlocking. Any mouldings present must be removed.

- If a dimension beyond the stop limits is entered, it is automatically reset to the limit position.

STANDARD SIZES:

The 999 Quick Stop/Smart Stop can also store 80 standard frames identified only by their length and width dimensions.

The standard frame menu is accessed either via the Main menu or via the Execution menu. There are 5 pages of 16 standard sizes. All the dimensions can be reprogrammed using the numeric keypad.

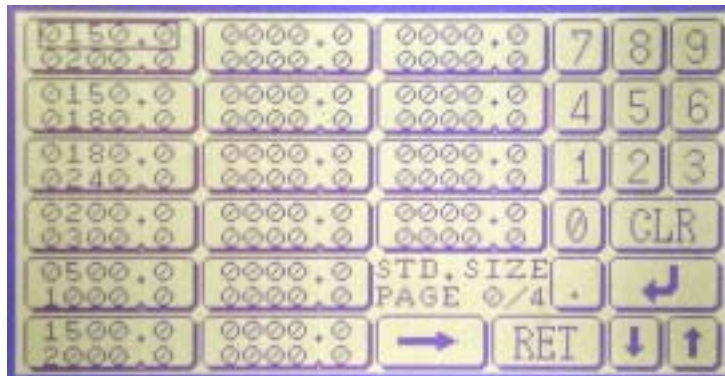

A frame is executed by touching its key: the execution screen will appear, allowing only the length and width values of the standard frame to be adjusted.

This allows standard frames to be combined with the SMART STOP measuring function or a stored file.

MENU MAINTENANCE PARAMETERS

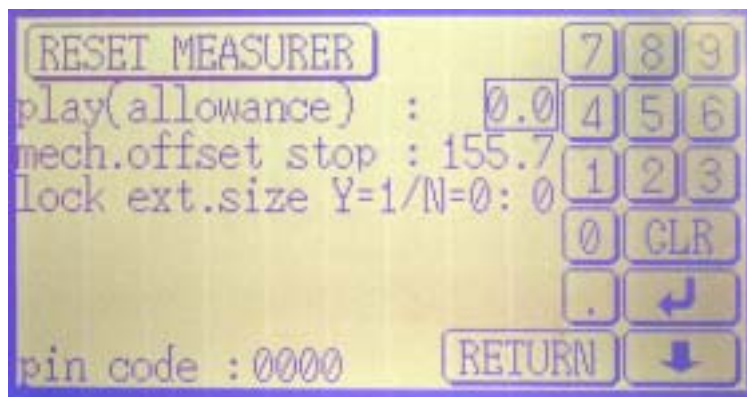

In the main menu, touch MAINTENANCE to access the parameters page.

All the values can be modified. There is no need to switch off the power for the new values to be acknowledged.

RESET MEASURER : Press the measurer button and this key simultaneously to reset the measurer origin, if it is incorrectly set. Beware: Take care to remove any moulding which could have stayed on the cutting table, near the left hand horizontal presser.

STANDARD PLAY: Type the play value allowance you wish to add automatically for internal dimension positioning, e.g. 1.5 mm.

STOP MECHANICAL OFFSET: Dimension at which the automatic stop is initialised each time the power is switched on and the EXECUTE key is touched for the first time. This dimension can be checked by cutting a moulding at 45° and measuring its thickness without rebate. If necessary this dimension can be adjusted each time a stop or coder is removed. In this case, check that the stop initialises approximately 2-3 cm beyond the proximity detector of the origin take-up area. Modify the offset value allows you to correct directly the stop's position, hence to compensate a possible measuring mistake.

LOCK EXT. SIZE : Type the value '1' if you do not wish the operator to be able to work with external dimensions (the INTER/EXTER keys will be disabled).

To release, type the value '0'.

PIN CODE: Reserved for maintenance.