

- Notes:
1. Assembly per the drawing.
  2. Qty for item #11: 0~3pcs
  3. Torsional force for screws: 15kgf min
  4. Old No.: P327-19.0

1	AS-00002216-	Cutting Head SUB-Assy.	1
2	AS-00002215-	Rocker Arm SUB-Assy	1
3	AS-00002217-	Slide EXT.Assy.	1
4	MA-00001082-	Handle Flat Head Screw	4
5	TU-00001087-	Bronze Bushing	1
6	MA-00001088-	Compression Spring	1
7	MA-00001047-	Retaining Ring	4
8	TU-00001089-	Shaft-Trigger	2
9	CA-00001008-	Trigger Sand Casting	1
10	MA-00001090-	Pillar Plst Knob	1
	MA-00001211-	t=0.05mm SS	0~3
	MA-00001212-	t=0.10mm SS	0~3
11	MA-00001214-	t=0.15mm SS	0~3
Item	ERP No.	Description	Qty

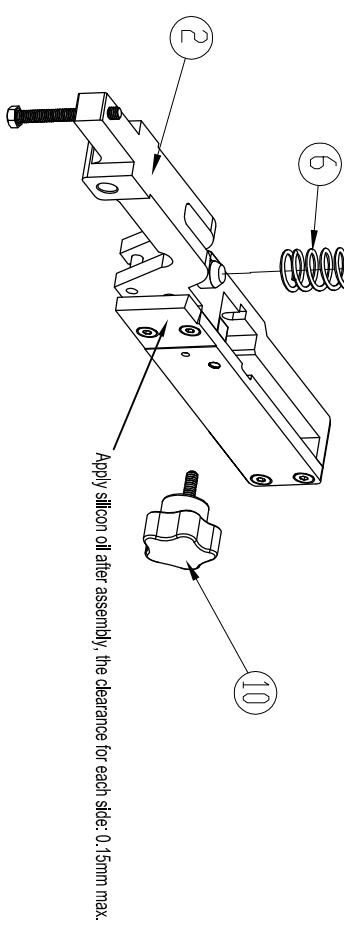

MODEL NO.	DWG NO.
P327	AS-00002218-00
TITLE:	
FSC Cutting Head Final Assy.	