



Instructions and Parts List

3M-Matic[™]

S867 Type 10500

"L" Clip

Applicator

Serial No. _____
For reference, record machine serial number here.



3M Industrial Adhesives and Tapes
3M Center, Building 220-5E-06
St. Paul, MN 55144-1000



Important Safety Information

BEFORE INSTALLING
OR OPERATING THIS
EQUIPMENT

Read, understand, and
follow all safety and
operating instructions.

Spare Parts

It is recommended you
immediately order the
spare parts listed in the
"Spare Parts/Service
Information" section.

These parts are expected
to wear through normal
use, and should be kept
on hand to minimize
production delays.



This instruction manual covers safety aspects, handling and transport, storage, unpacking, preparation, installation, operation, adjustments, maintenance, troubleshooting, repair work and servicing plus parts list of the **3M-Matic S867 L-Clip Applicator**.

3M Industrial Adhesives and Tapes
3M Center, Building 220-5E-06
St. Paul, MN 55144-1000

Edition June 2013

Copyright 3M 2013
All rights reserved

The manufacturer reserves the right to change the product at any time without notice.

Replacement Parts and Service Information

To Our Customers:

This is the 3M-Matic™/AccuGlide™/Scotch® equipment you ordered. It has been set up and tested in the factory with Scotch® tapes. If technical assistance or replacement parts are needed, call or fax the appropriate number.

Included with each machine is an Instructions and Parts List manual.

Technical Assistance / Replacement Parts and Additional Manuals:

Contact your local service provider. Provide the customer support coordinator with the model/machine name, machine type, and serial number that are located on the identification plate (For example: Model S867 - Type 40800 - Serial Number 13282).

Identification Plate

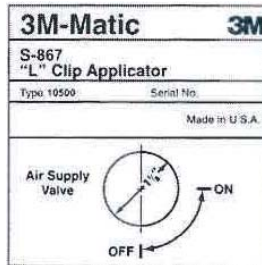

3M Industrial Adhesives and Tapes
3M Center, Building 220-5E-06
St. Paul, MN 55144-1000

3M-Matic™, AccuGlide™ and Scotch™
are Trademarks of
3M St. Paul, MN 55144-1000
Printed in U.S.A.

Replacement Parts and Service Information

To Our Customers:

This is the 3M-Matic™/AccuGlide™/Scotch® equipment you ordered. It has been set up and tested in the factory with Scotch® tapes. If technical assistance or replacement parts are needed, call or fax the appropriate number listed below.

Included with each machine is an Instructions and Parts List manual.

Technical Assistance:

Call the 3M-Matic™ Helpline at 1-800-328-1390. Provide the customer support coordinator with the model/machine name, machine type, and serial number that are located on the identification plate. If you have a technical question that does not require an immediate response, you may fax it to 1-651-736-7282.

Replacement Parts and Additional Manuals

Order parts by part number, part description, and quantity required.

When ordering parts or additional manuals, include model/machine name, machine type, and serial number that are located on the identification plate (For example: S867 L-Clip Applicator - Type 10500 - Serial Number 13282).

3M Tape Dispenser Parts

241 Venture Drive

Amery, WI 54001-1325

1-800-344-9883

Fax: 1-715-268-8153

Minimum billing on parts orders will be \$25.00. Replacement part prices available on request.

\$10.00 restocking charge per invoice on returned parts.

Note: Outside the U.S., contact the local 3M subsidiary for parts ordering information.



3M Industrial Adhesives and Tapes

3M Center, Building 220-5E-06
St. Paul, MN 55144-1000

3M-Matic™, AccuGlide™ and
Scotch™ are Trademarks of
3M, St. Paul, MN 55144-1000

TABLE OF CONTENTS: S-867 “L” Clip Applicator, Type 10500

S-867 “L” Clip Applicator	Page
Cover Page	
Replacement Parts and Service Information	i-ii
Table of Contents	iii-iv
Acronyms and Abbreviations	v
1. Introduction	
1.1 Intended Use	1
1.2 How to Read and Use the Manual	2
1.2.1 Importance of the Manual	2
1.2.2 Manual Maintenance	2
1.2.3 Consulting the Manual	2
1.2.4 How to Update the Manual in Case of Modifications	2
2. General Information	
2.1 Identification Data	3
2.2 Warranty / Contents	4
3. Important Safeguards	
3.1 Signal Words Explanation	5
3.2 Table of Warnings	5
3.3 Operator’s Qualifications Definition	6
3.4 Table of Warnings and Replacement Labels	7
4. Technical Specifications	
4.1 Tape Specifications	8
4.2 Air Power Requirements	8
4.3 Box Size Capacity	8
4.4 Cycle Time	8
4.5 Operating Conditions	8
4.6 Machine Dimensions	8
5. Installation and Set-Up	
5.1 Receiving and Handling	9
5.2 Machine Set-Up	9
5.3 Mounting	9 - 10
5.4 Air Regulator / Filter	11
5.5 Tape Drum - Bracket Assembly	12

(Table of Contents continued on next page)

THIS PAGE IS BLANK

TABLE OF CONTENTS (continued)

6. Theory of Operation

6.1 General Information 13
6.2 Operational Explanation 13
 Rest Position, Air Off 13
 Rest Position, Air On 13
 Application Cycle, Cut / Buff Sequence 14
 Application Cycle, Feed Sequence 15
6.3 Components 16
 Valves 16
 Cylinders 16

7. Operation

7.1 Tape Loading and Threading 17
7.2 Operating Sequence 18

8. Adjustments

8.1 Tape Width 19
8.2 Tape Web Alignment 19
8.3 Tape Drum Tension 19
8.4 Tape Tension Roller 19
8.5 V-8 Valve Adjustment 19
8.6 Air Flow Controls 19

9. Maintenance

9.1 Blade Replacement 20
9.2 Air Line Filter 20

10. Troubleshooting

10.1 Pneumatic Schematic 21
10.2 Troubleshooting Guide 22 - 23
10.3 Air Line Connections / Tubing Length 24

11. Replacement Parts and Service Information

11.1 Recommended Spare Parts 26
11.2 How To Order Replacement Parts 26
11.3 Repair Service 26

Drawings and Parts Lists 27 - 46

12. Typical Mounting Set-Up / Single Head Stand

12.1 Purpose of Attachment 47

13. Specifications

13.1 Parts 47
13.2 Overall Dimensions 47
13.3 Work Surface Height 47
13.4 Work Surface Size 47
13.5 Work Surface Weight 47

14. Assembly Instructions

14.1 Single Head Stand 48 - 49
14.2 Work Surface Height 49
14.3 Instructions 49
14.4 Warranty 51

ABBREVIATIONS AND ACRONYMS

LIST OF ABBREVIATIONS AND ACRONYMS

3M-Matic	- Trademark of 3M St. Paul, MN 55144-1000
Scotch	- Trademark of 3M St. Paul, MN 55144-1000
Drw.	- drawing
Ex.	- for example
Fig.	- exploded view figure no. (spare parts)
Figure	- Illustration
Max.	- maximum
Min.	- minimum
Nr.	- number
N/A	- not applicable
OFF	- machine not operating
ON	- machine operating
PLC	- Programmable Logic Control
PP	- Polypropylene
PTFE	- Polytetrafluorethelene
PU / PU-Foam	- Polyurethane Foam
PVC	- Poly-vinyl chloride
W	- Width
H	- Height
L	- Length

1 - Introduction

1.1 Intended Use:

The intended use of the **S-867 "L" Clip Applicator** is to apply an "L" clip of **Scotch®** filament tape to most box corners.

The machine is designed for installation adjacent to a conveyor system or on a stand for off-line systems, the **S-867** allows the operator to quickly apply the "L" clip box closure. When a box is inserted into the

nest, the product paddle is depressed and the air operating mechanism which applies the "L" clip tape closure is activated causing the "L" clip to be automatically applied to the box corner.

The **S-867 "L" Clip Applicator** has been designed and tested for use with **Scotch®** filament and strapping tape.

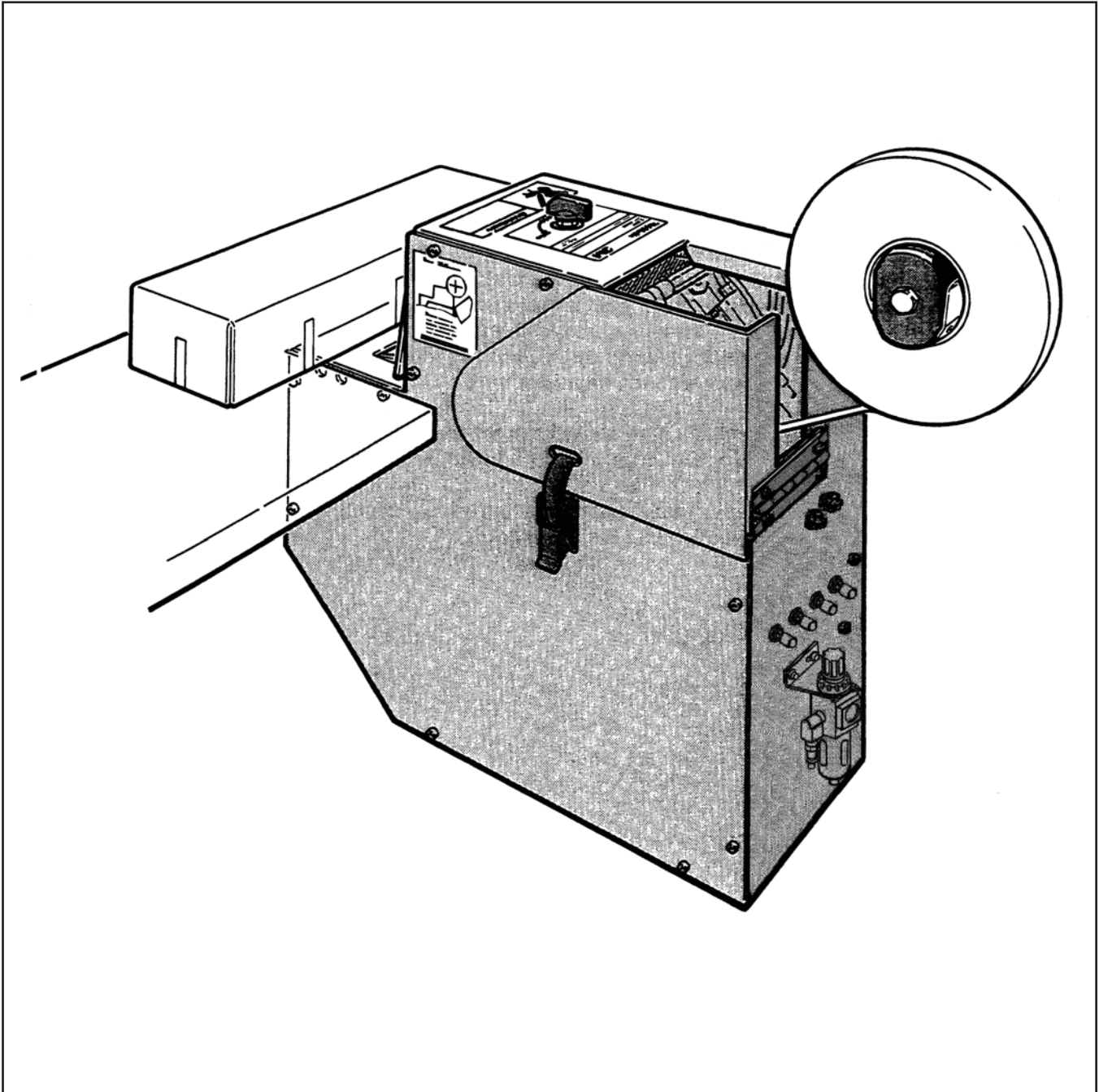

3M-Matic™ S-867 "L" Clip Applicator, Type 10500

1.1 Manufacturing Specifications / Description / Intended Use (continued)

The 3M-Matic™ case sealing machines have been designed and manufactured in compliance with the legal requirements at the date of inception.

1.2 How to Read and Use the Instruction Manual

This instruction manual covers safety aspects, handling and transport, storage, unpacking, preparation, installation, operation, Setup and adjustments, technical and manufacturing specifications, maintenance, troubleshooting, repair work and servicing, electric diagrams, warranty information, disposal (ELV), a definition of symbols, plus a parts list of the 3M-Matic™ **S-867 "L" Clip Applicator** 3M Industrial Adhesives and Tapes Division 3M Center, Bldg. 220-5E-06 St. Paul, MN 55144-1000 (USA) Edition June 2013 Copyright 3M 2010 All rights reserved. The manufacturer reserves the right to change the product at any time without notice. Publication © **3M 2013 44-0009-2041-1.**

1.2.1 Importance of the Manual

The manual is an important part of the machine; all information contained herein is intended to enable the equipment to be maintained in perfect condition and operated safely. Ensure that the manual is available to all operators of this equipment and is kept up to date with all subsequent amendments. Should the equipment be sold or disposed of, please ensure that the manual is passed on. Electrical and pneumatic diagrams are included in the manual. Equipment using PLC controls and/or electronic components will include relevant schematics or programs in the enclosure and in addition, the relevant documentation will be delivered separately.

1.2.2 Manual Maintenance

Keep the manual in a clean and dry place near the machine. Do not remove, tear, or rewrite parts of the manual for any reason. Use the manual without damaging it. In case the manual has been lost or damaged, ask your after-sale service for a new copy.

1.2.3 Consulting the Manual

The manual is composed of:

- Pages which identify the document and the machine
- Index of the subjects
- Instructions and notes on the machine
- Enclosures, drawings and diagrams
- Spare parts (last section)

All pages and diagrams are numbered. The spare parts lists are identified by the figure identification number. All the notes on safety measures or possible dangers are identified by the symbol:



1.2.4 How to Update the Manual in Case of Modifications to the Machine

Modifications to the machine are subject to manufacturer's internal procedures. The user receives a complete and up-to-date copy of the manual together with the machine. Afterwards the user may receive pages or parts of the manual which contain amendments or improvements made after its first publication. The user must use them to update this manual.

2 - General Information

2.1 Data Identifying Manufacturer and Machine

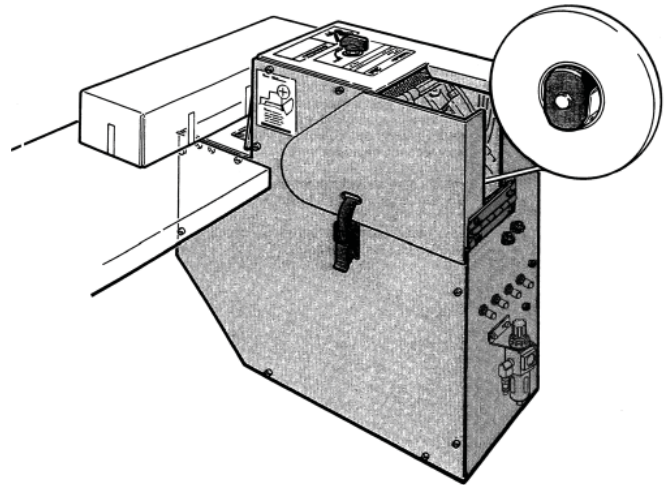

Identification Plate

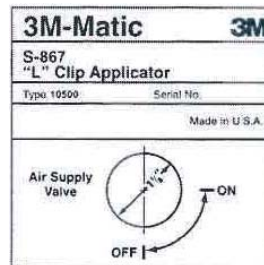

Equipment Warranty and Limited Remedy: THE FOLLOWING WARRANTY IS MADE IN LIEU OF ALL OTHER WARRANTIES, EXPRESS OR IMPLIED, INCLUDING, BUT NOT LIMITED TO, THE IMPLIED WARRANTY OF MERCHANTABILITY, THE IMPLIED WARRANTY OF FITNESS FOR A PARTICULAR PURPOSE AND ANY IMPLIED WARRANTY ARISING OUT OF A COURSE OF DEALING, A CUSTOM OR USAGE OF TRADE:

3M warrants that its **3M-Matic™ S-867 "L" Clip Applicator, Type 10500** will be free from defects for ninety (90) days after delivery. If any part is proved to be defective within the warranty period, then the exclusive remedy and 3M's and seller's sole obligation shall be, at 3M's option, to repair or replace the part, provided the defective part is returned immediately to 3M's factory or an authorized service station designated by 3M. A part will be presumed to have become defective after the warranty period unless the part is received or 3M is notified of the problem no later than five (5) calendar days after the warranty period. If 3M is unable to repair or replace the part within a reasonable time, then 3M, at its option, will replace the equipment or refund the purchase price. 3M shall have no obligation to provide or pay for the labor required to install the repaired or replacement part. 3M shall have no obligation to repair or replace (1) those parts failing due to operator misuse, carelessness, or due to any accidental cause other than equipment failure, or (2) parts failing due to non-lubrication, inadequate cleaning, improper operating environment, improper utilities or operator error.

Limitation of Liability: 3M and seller shall not be liable for direct, indirect, special, incidental or consequential damages based upon breach of warranty, breach of contract, negligence, strict liability or any other legal theory.

The foregoing Equipment Warranty and Limited Remedy and Limitation of Liability may be changed only by a written agreement signed by authorized officers of 3M and seller.

"Scotch" and "3M-Matic" are trademarks of 3M, St.Paul, Minnesota 55144-1000

S-867 Contents

- (1) S-867 "L" Clip Applicator, Type 10500
- (1) Instruction and Parts List Manual

3 - Important Safeguards

3.1 Explanation of Signal Word and Possible Consequences

	This safety alert symbol identifies important messages in this manual. READ AND UNDERSTAND THEM BEFORE INSTALLING OR OPERATING THIS EQUIPMENT.
---	--

 **CAUTION:** Indicates a potentially hazardous situation, which, if not avoided, may result in minor or moderate injury and/or property damage.

 **WARNING:** Indicates a potentially hazardous situation, which, if not avoided, could result in death or serious injury and/or property damage.

3.2 Table of Warnings

 WARNING
<ul style="list-style-type: none">• To reduce the risk associated with mechanical and pneumatic hazards:<ul style="list-style-type: none">- Read, understand and follow all safety and operating instructions before operating or servicing the case sealer- Allow only properly trained and qualified personnel to operate and/or service this equipment- Never attempt to defeat the machine guard interlock• To reduce the risk associated with pinch and entanglement hazards:<ul style="list-style-type: none">- Turn air supply off and disconnect before performing any adjustments, maintenance or servicing the machine- Turn the machine off while not in use- Never attempt to work on any part of the machine or load tape while the machine is running

 WARNING (continued)
<ul style="list-style-type: none">• To reduce the risk associated with sharp blade hazards:<ul style="list-style-type: none">- Keep hands and fingers away from tape cutoff blades under orange blade guards. The blades are extremely sharp• To reduce the risk associated with muscle strain:<ul style="list-style-type: none">- Use the appropriate rigging and material handling equipment when lifting or repositioning this equipment

 CAUTION
<ul style="list-style-type: none">• To reduce the risk associated with pinch and entanglement hazards:<ul style="list-style-type: none">- Always feed boxes into the machine by pushing only from the end of the box- Keep hands, hair, loose clothing, and jewelry away from opening in the nest

3 - Important Safeguards (continued)

 WARNING
<ul style="list-style-type: none"> • To reduce the risk associated with mechanical and pneumatic hazards: <ul style="list-style-type: none"> – Read, understand and follow all safety and operating instructions before operating or servicing the case sealer – Allow only properly trained and qualified personnel to operate and/or service this equipment

Skill 2 - Mechanical Maintenance Technician

This operator is trained to use the machine as the MACHINE OPERATOR and in addition is able to work with the safety protection disconnected, to check and adjust mechanical parts, to carry out maintenance operations and repair the machine.

Skill 3 - Specialist From the Manufacturer

Skilled operator sent by the manufacturer or its agent to perform complex repairs or modifications, when agreed with the customer.

3.3 Operator Qualifications

Operator Skill Level Descriptions

Skill 1 - Machine Operator

This operator is trained to use the machine with the machine controls, to feed cases into the machine, to change the tape and to start, stop and restart production.

Important – the factory manager must ensure that the operator has been properly trained on all the machine functions before starting work.

Operator's Skill Levels Required to Perform the Main Operations on Machine

Operation	State of the Machine	Operator's Skill	Number of Operators
Installation and set up of the machine.	Running with safety protections disabled.	2	1
Tape replacement.	Main air valve in the "off" position or air supply disconnected.	1	1
Replacement of blades.	Air supply disconnected.	2	1
Ordinary maintenance.	Air supply disconnected.	2	1
Extraordinary maintenance (mechanical).	Running with safety protections disabled.	3	1

3 - Important Safeguards (continued)

3.4 Table of Warnings and Replacement Labels

Important – In the event the following safety labels are damaged or destroyed, **they must be replaced to ensure operator safety**. Replacement part numbers for individual labels are shown in **Figure 3-1**, or a label kit part number 78-8137-0223-6, is available that includes all labels used on the machine.

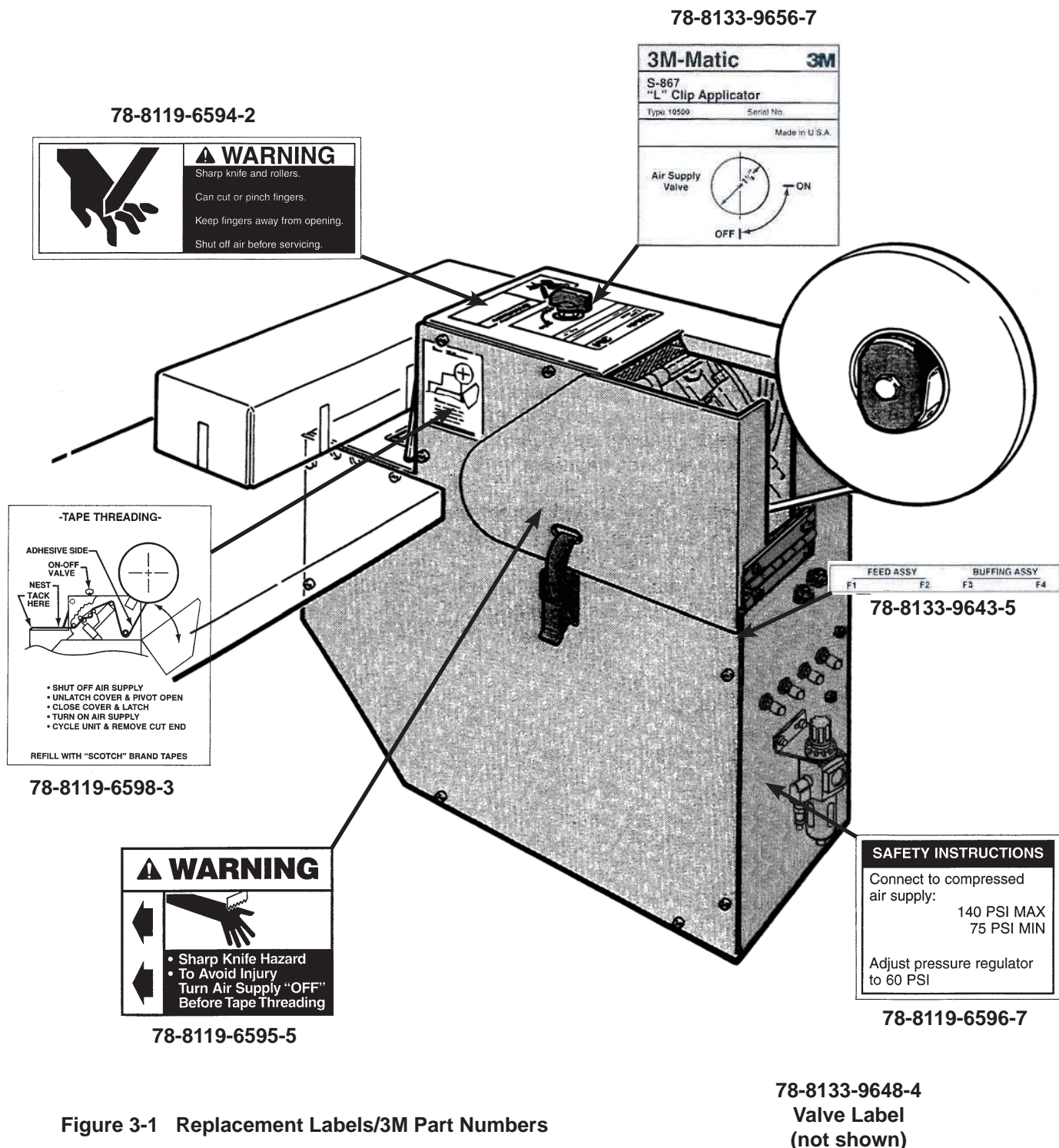

Figure 3-1 Replacement Labels/3M Part Numbers

4 - Specifications

4.1 Tape Specifications:

Tape – Most "**Scotch**" brand filament tapes.

Tape Width – 3/8 inch [9mm] to
1 1/2 inch [36mm].

Tape Roll Diameter – Up to 15 inches [380mm]
maximum on a 3 inch [76.2mm] diameter core.

Applied Tape Length – 4 1/2 inches [115mm]
(nominal). Tape legs are 2 1/4 ±1/8 inches
[55 mm ± 3.2mm].

4.2 Air Power Requirements:

60 to 65 PSIG [415 to 450 kPa] gauge pressure.

2.16 SCFM [3.65 m³/h 21°C, 101 kPa] at
50 cycles/min

4.3 Box Size Capacity:

Bottom or Top Taping Position
Height – 2 1/4 inches [60mm] minimum to
unlimited maximum

Width – 3 inches [75mm] minimum to
unlimited maximum

Depth – 2 1/4 inches [60mm] minimum to
unlimited maximum

Note: Operator capability will determine maximum height, width, and depth. Smaller heights and widths are sometimes possible and it is recommended that your 3M Representative be contacted for testing of these applications.

4.4 Cycle Time:

1.2 seconds per cycle

The cycle time is sufficient to satisfy the majority of applications. Flow controls (see Machine Setup and Adjustments section) control the application rate and return stroke rate of the buffing and tape feed air cylinders. While these flow controls can be adjusted for increased speed, this practice may result in higher maintenance costs and shorten machine life.

4.5 Operating Conditions:

Use in dry, relatively clean environments at 40°
to 120°F [5° to 49°C] with clean, dry boxes.

Important – Machine should not be washed down or subjected to conditions causing moisture condensation on components.

4.6 Machine Dimensions:

Length – 31 inches [790mm]
(includes 360 yard [330m] tape roll)

Height – 29 inches [735mm]
(includes 360 yard [330m] tape roll)

Width – 11 inches [280mm]

Weight – Packaged 83 lb [37.7 kg]
Unpackaged 75 lb [34 kg]

5 - Installation and Set-Up

5.1 Receiving and Handling

After the applicator has been unpacked, examine it thoroughly for any damage that may have occurred during transit. **If damage is evident, file a damage claim immediately** with the transportation company and also notify your 3M Representative.

5.2 Machine Set-Up

Read the installation instructions through completely before performing the set-up procedure. Refer to the back of this manual for literature on "Typical Mounting Set-Up" for the **S-867** Applicator.



WARNING

- **To reduce the risk associated with muscle strain:**
- Use the appropriate rigging and material handling equipment when lifting or repositioning this equipment

5.3 Mounting

The **S-867** can be set up in either of three taping positions:

Bottom Taping Position – Shown in **Figure 5-1**. For application of "L" clip tape seal to the bottom corner of a box.

Top Taping Position – Contact your 3M representative for details on this mounting orientation.

Side Taping Position – Shown in **Figure 5-2**. For application of a tape seal to the end of a box.

Three mounting areas have been provided on the **S-867** main frame. A mounting bracket (with two holes) and a single mounting hole on the left side and two mounting holes located on the front of the machine. It is suggested that the **S-867** be mounted securely at any two of these mounting areas.

Note: When mounting the unit, always align the top surface of the nest parallel with the work surface. When mounting the unit for side taping align the nest perpendicular to the work surface.

It is suggested that a secondary height adjustment be provided for head adjustments as referred to in the top taping operation section.

Note: The air flow control unit must be remounted in a vertical position when operating the **S-867** in the top or side taping position. All additional brackets, fittings and air lines are to be supplied by the customer.

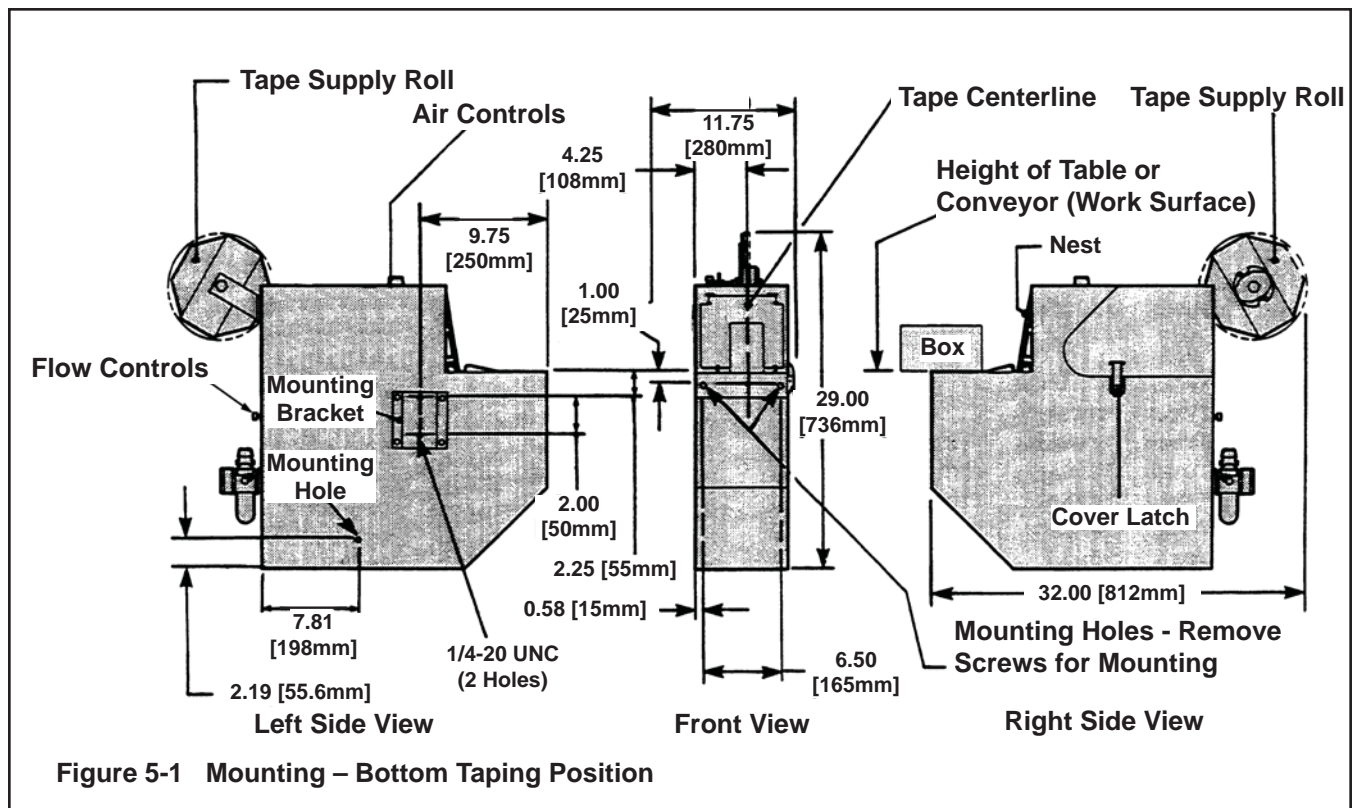

Figure 5-1 Mounting – Bottom Taping Position

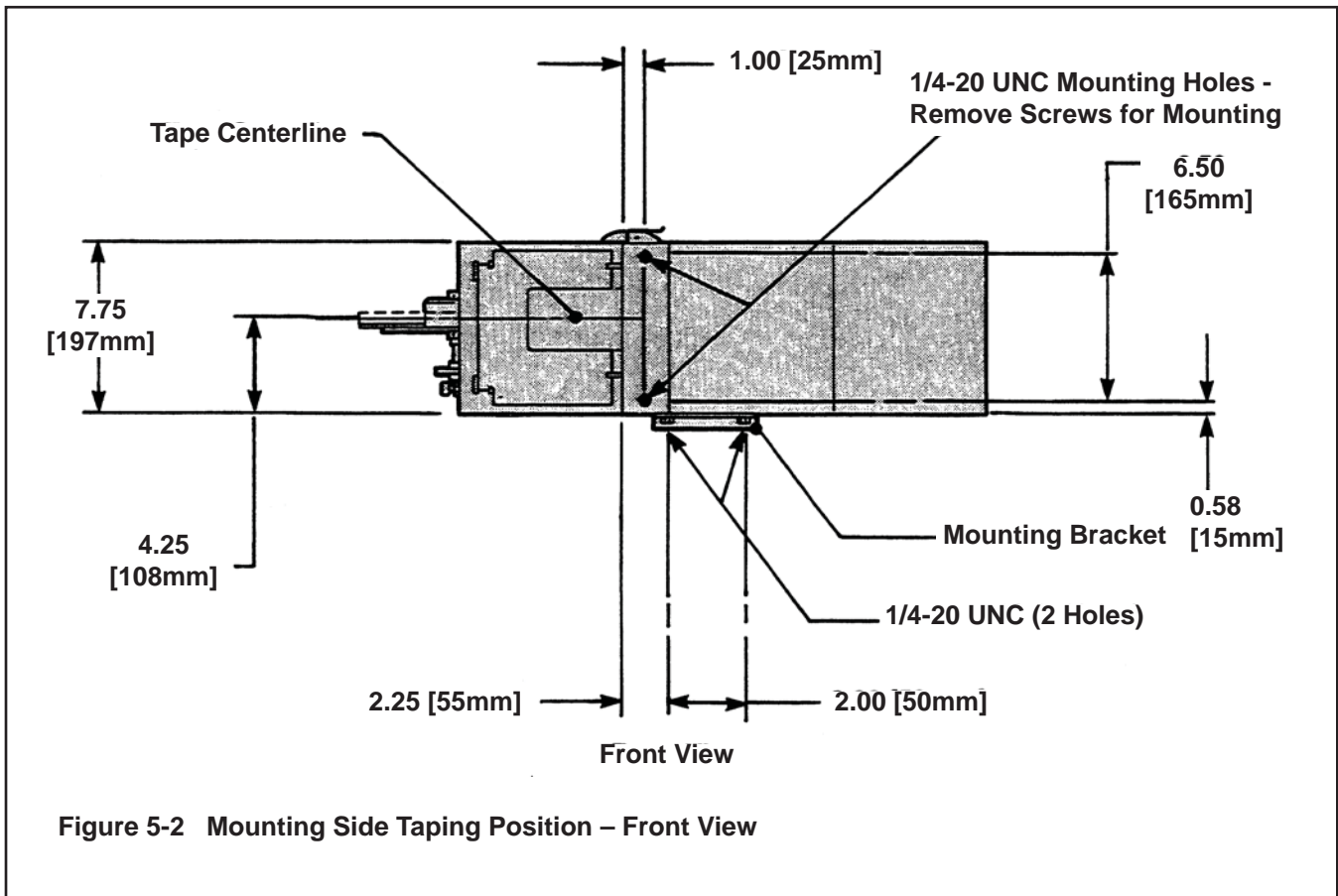

Figure 5-2 Mounting Side Taping Position – Front View

5.4 Air Regulator / Filter

The air control unit is supplied with two (2) mounting screws. Install the unit on the main frame, lower rear side, in the mounting holes provided.

1. Refer to **Figure 5-3** and locate the air control unit (A) in a vertical position for proper operation. Assemble and secure the two 8-32 x 1/2 lg. screws and flat washers.
2. Refer to **Figure 5-4** and push the air line (B) onto the male elbow (C) on the right side of the air control unit as shown.

3. Connect main air supply line.

Note: The main air supply line and required fittings are to be supplied by customer.

Turn On/Off valve on **S-867** to "Off" (O) position. See **Figure 5-3**.

Connect main air supply line to main air supply inlet on air regulator. See **Figure 5-4**.

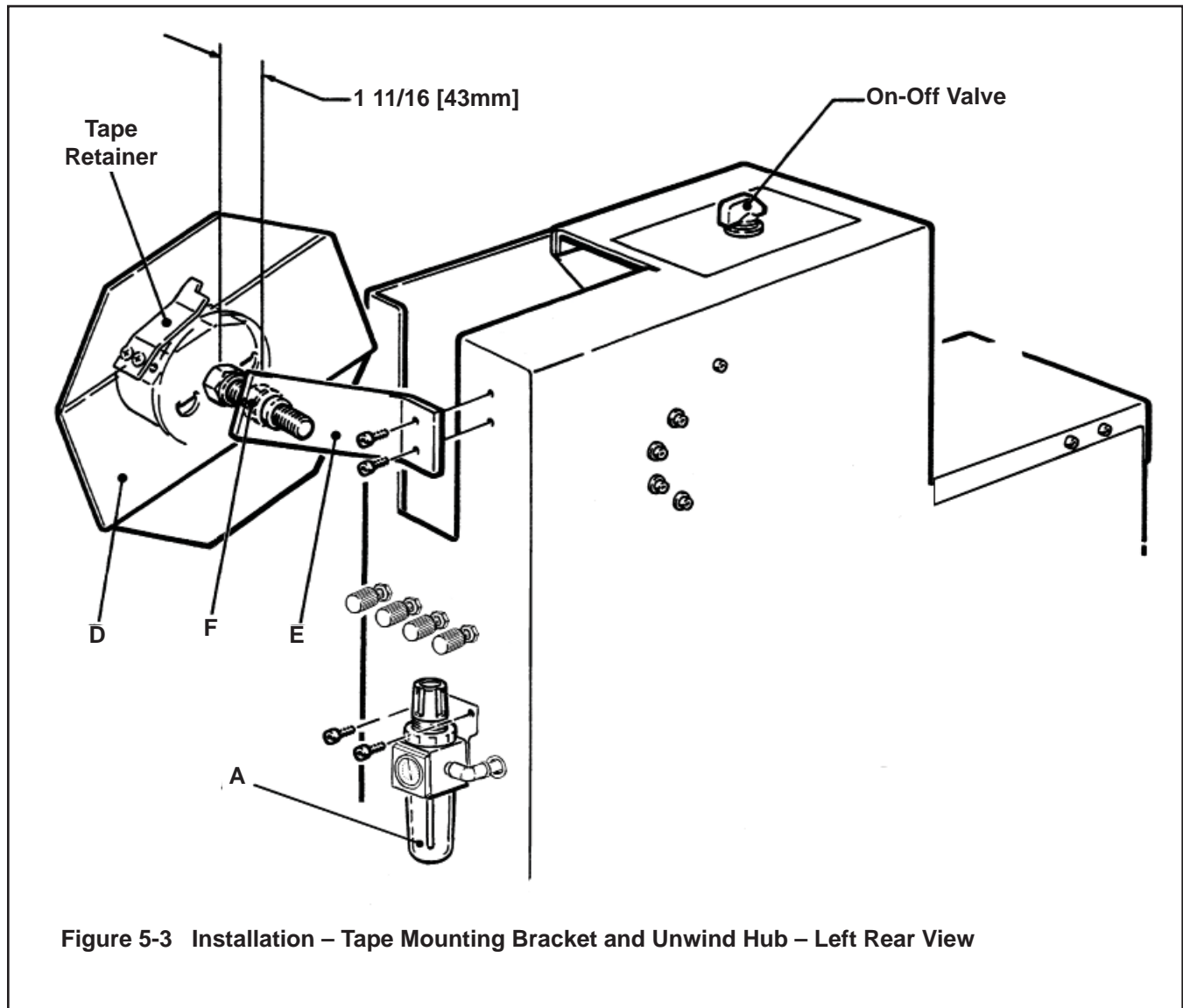

Figure 5-3 Installation – Tape Mounting Bracket and Unwind Hub – Left Rear View

5.5 Tape Drum - Bracket Assembly

The tape drum bracket is supplied with two #10-24 x 1/2 lg mounting screws. Assemble the bracket to the machine and the tape drum to the bracket.

1. Attach the tape drum bracket (E) to the rear of the machine with two #10-24 x 1/2 lg soc hd capscrews as shown in **Figure 5-3**.

2. Assemble the tape drum/backup plate (D) to the bracket (E) and adjust tape drum/backup plate in or out to obtain the 1-11/16 inch [43 mm] clearance between backup plate and bracket as shown in **Figure 5-3**. Secure this setting with the 1/2-13 jam nut (F).

Tape Loading and Threading

See "Operations Section."

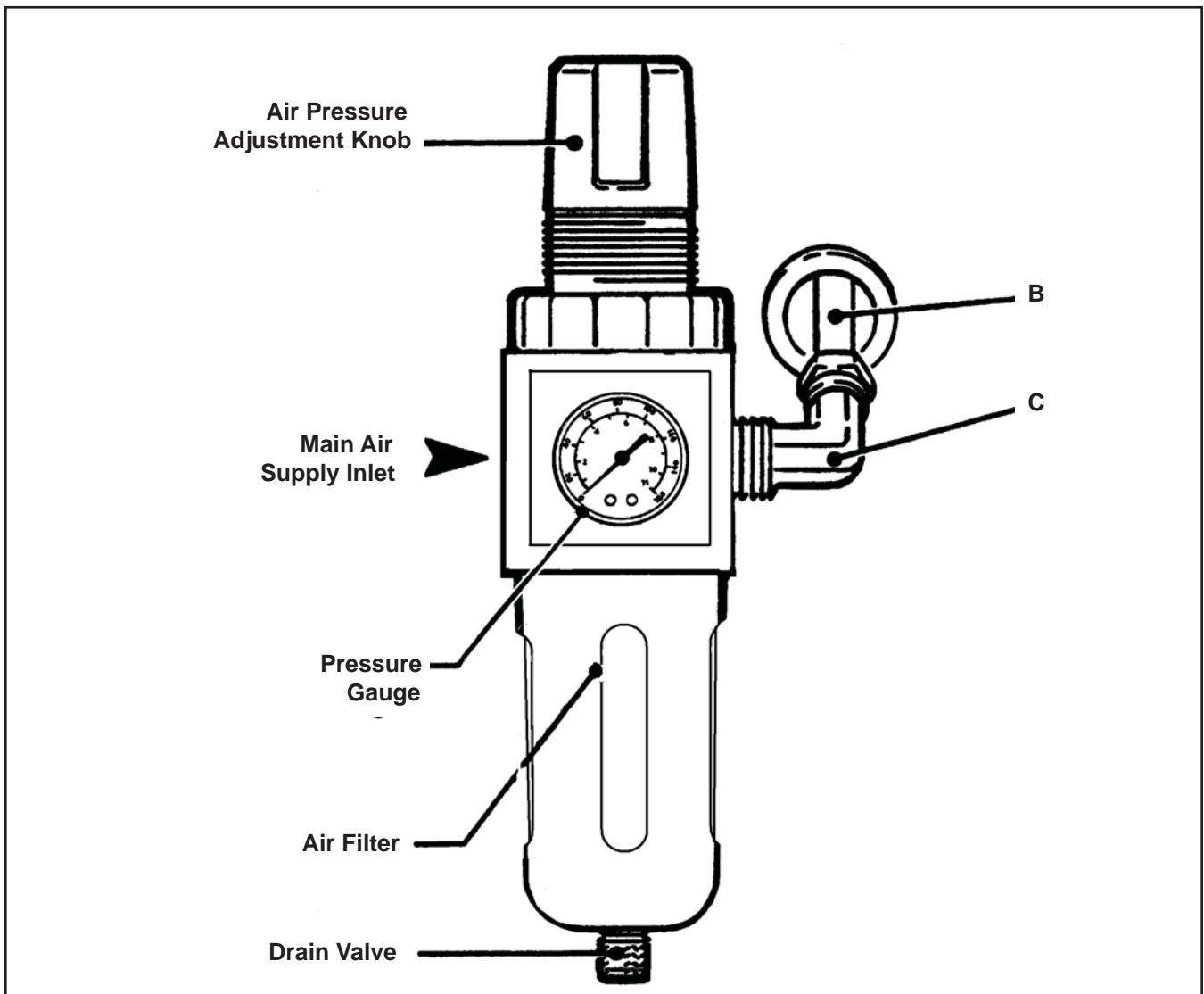

Figure 5-4 Air Control Unit – Set-Up

6 - Theory of Operation

This section contains general information about the **S-867**, a pneumatic schematic, detailed operational explanation and a pneumatic components list.

6.1 General Information

The **S-867** is a pneumatically powered machine containing eleven pneumatic valves and six pneumatic cylinders. These components are all listed at the end of this section with a brief description of their function.

The machine consists of four primary assemblies listed below.

- Knife assembly – cuts the section of tape to be applied.
- Buff assembly – applies the section of tape to the box corner.
- Feed assembly – advances the tape between applications.
- Jaw assembly – retains the free end of the tape between applications.

6.2 Operational Explanation

Rest Position, Air Off

When the machine is in rest position with the air off, a spring-actuated air cylinder extends to hold up the feed assembly. **See Figure 6-1.** This is necessary because the air cylinder is in the fully extended position. Without the spring-actuated air cylinder, the weight of the feed assembly could cause the air cylinder to retract and damage the section of tape ready for application.

Rest Position, Air On

When air is applied to the machine, it is routed through the On/Off control valve V-1, through line 2, through safety valve V-9, and into the manifold through line 28. **See Figure 6-1.**

The manifold then routes the air to seven locations. Four of the routes from the manifold direct air to valves that are closed when the machine is in the rest position. These "blocked" air routes are:

- Through line 3 to valve V-2
- Through line 25 to valve V-3
- Through line 24 to valve V-4
- Through line 18 to valve V-6

The remaining three routes direct air to actuate the air cylinders and prepare the machine for the application cycle.

- Air is directed through line 29 to retract the spring-loaded safety cylinder that retains the feed mechanism.
- Air is directed through line 27 to the pilot valve P-1. The air exits the pilot valve and is branched to retract the buff and cut cylinders. The pilot valve directs air through line 9, the buff cylinder retract flow control valve, and line 21 to the rod end of the buff cylinder to retract the cylinder, and through line 8 to the rod end of the cut cylinder and retracts it also.
- Air is also directed through line 7 to pilot valve P-2. The air exits the pilot valve P-2 and is branched to extend the feed and jaw cylinders. Air travels from the pilot valve through line 14, valve V-5, and line 26 to the head end of the jaw cylinder and extends the cylinder. Air is also directed through line 15, valve V-7, line 19, the feed cylinder extend flow control valve, and line 22 to the head-end of the feed cylinder and extends the feed cylinder.

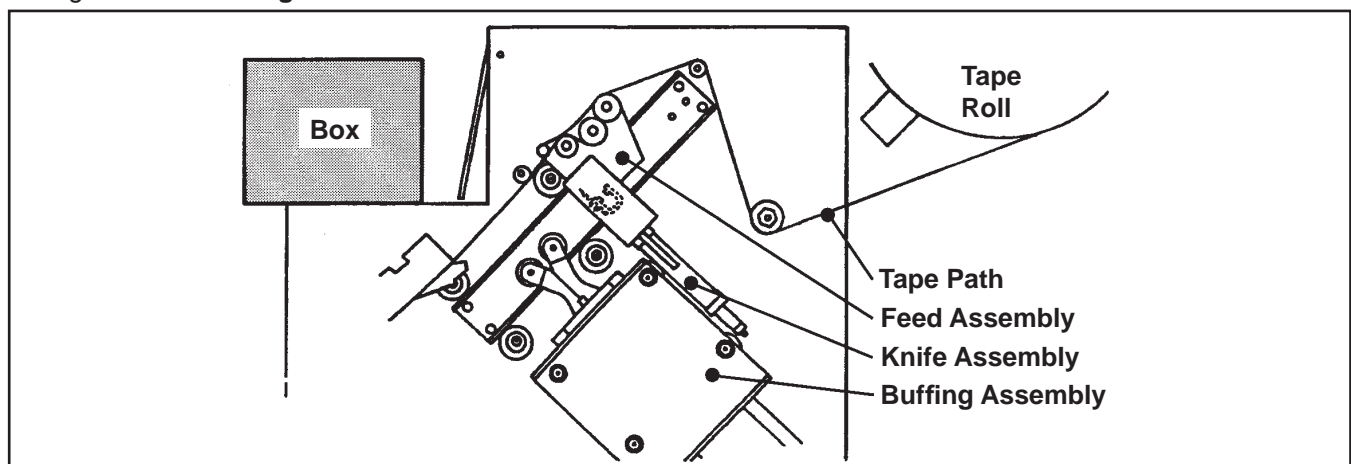

Figure 6-1 Rest Position

Application Cycle, Cut / Buff Sequence

When the machine is in the powered rest position and a box is placed in the nest area, the box paddle actuates valve V-2. This allows a pulse of air to flow from the manifold through valve V-2, line 4, valve V-8, and line 5 to the PA port of the pilot valve P-1. This shifts the pilot valve P-1. Air is then directed to the paddle cylinder, which holds the paddle to the machine housing, which prevents the additional actuation of paddle valve V-2 before the application cycle is completed.

Air is then directed to the head end of the cut and buff cylinders and causes both to extend at the same time. At full extension, a section of tape is cut by the knife assembly and immediately applied to the box by the buff roller assembly.

As the buff assembly reaches full extension, it actuates valve V-3. This directs a pulse of air to the PB port of the pilot valve P-1 causing it to shift and direct air to the rod end of the cut and buff cylinders. This causes the cut and buff cylinders to retract and return the knife and buff assemblies back to the machine rest position. Shortly before the buff cylinder fully retracts, it actuates valve V-4. This begins the feed sequence.

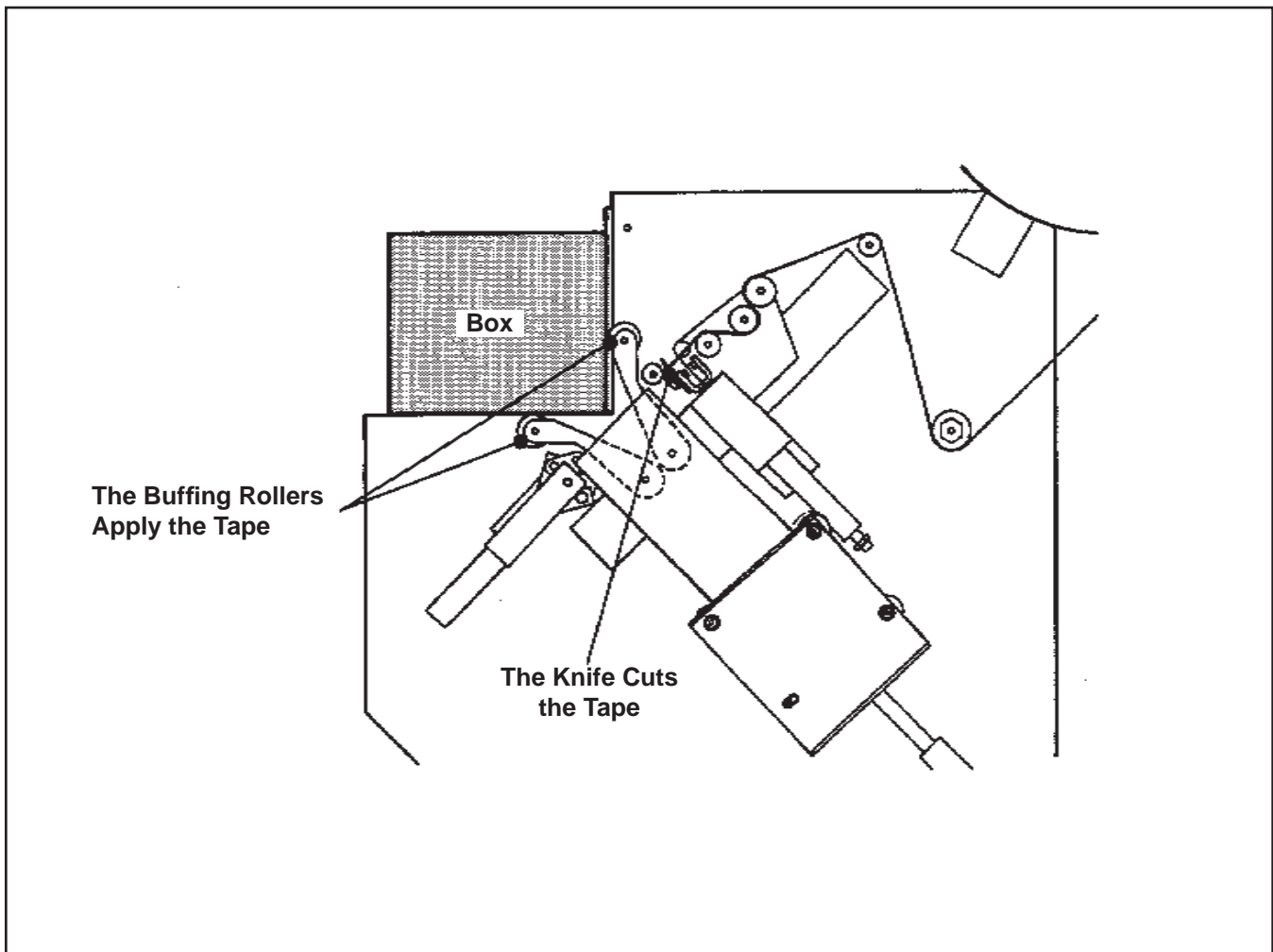

Figure 6-2 Cut / Buff Sequence

Application Cycle, Feed Sequence

Valve V-4 directs air to the PA port of the pilot valve P-2 causing it to shift and direct air to the rod end of the jaw and feed cylinders. Air travels from the pilot valve P-2 through line 17, the feed cylinder retract flow valve, and line 23 to the rod end of the feed cylinder and through line 16 to the rod end of the jaw cylinder. As the cylinders retract, the jaws on the jaw assembly open to receive the tape that the feed assembly is advancing. As the feed assembly advances, the tape pick up roller pivots upward out of the path of the feed assembly. At the end of its stroke, the feed assembly actuates valve V-6 which directs a pulse of air to the PB port of the pilot valve P-2. This causes valve P-2 to shift and direct air through line 14, valve V-5, and line 26 to the head end of the jaw cylinder. The jaw cylinder extends and the tape holding jaws close to retain the free end of the tape advanced by the feed assembly.

When the jaw cylinder is completely extended, the jaws close and retain the free end of the tape and valve V-7 is actuated. Valve V-7 directs air to the head end of the feed cylinder. This causes the feed mechanism to move back to the machine rest position. The machine is now ready for the next cycle.

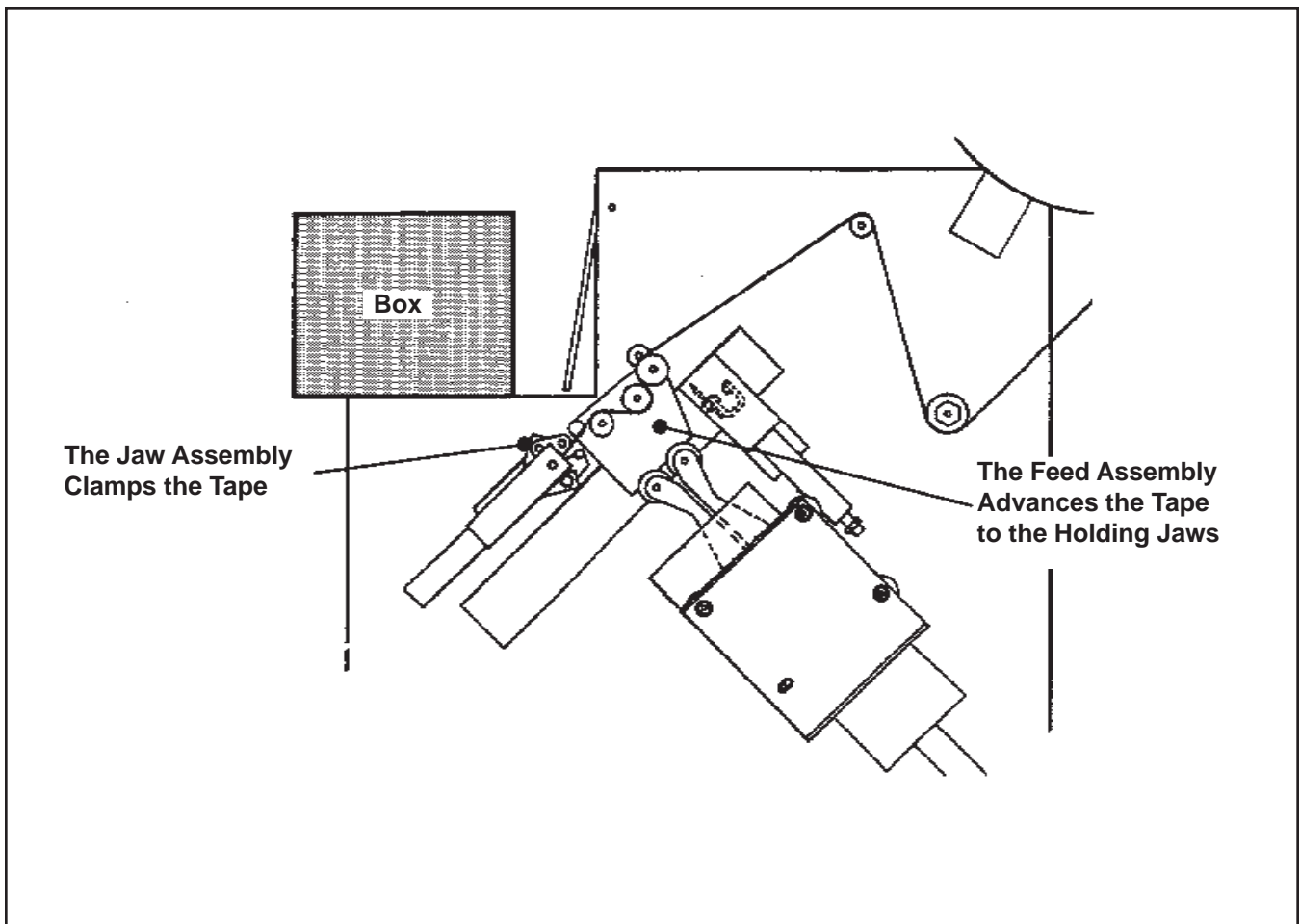

Figure 6-3 Feed Sequence

6.3 Components

Refer to **Figure 6-1** for component locations.

Valves

V-1: The on/off control valve, actuated by the knob on the top of the machine.

V-2 Paddle Valve: A box placed in the paddle area actuates V-2, which directs a pulse of air from the manifold, through valve V-8, to the PA port of pilot valve P-1. This shifts valve P-1 and activates the buff and cut cylinders beginning the application cycle.

V-3: This valve is actuated by an actuator on the buff cylinder slide assembly and directs air to the PB inlet of valve P-1, thus causing it to shift and retract the buff and cut cylinders.

V-4: This valve is actuated by an actuator on the buff cylinder slide assembly and routes air to the PA port of the pilot valve P-2. This causes valve P-2 to shift and direct power to the feed and jaw cylinders to begin the feed sequence.

V-5: Actuated by the buff cylinder slide assembly at the end of the retract stroke, V-5 directs air from the pilot valve V-2 to the jaw cylinder.

V-6: Actuated by the feed cylinder slide assembly at the end of the retract stroke, V-6 shifts the pilot valve P-2 and causes extension of the jaw cylinder. This causes the tape holding jaws to close on the free end of the tape.

V-7: Valve V-7 is actuated by the actuator mounted on the jaw cylinder rod. When the jaw cylinder fully extends, valve V-7 actuates and directs air to the head-end of the feed cylinder, causing the feed cylinder retract. This completes the feed cycle.

V-8: Actuated by the full extension of the feed cylinder assembly, valve V-8 provides a path for air from paddle valve V-2 to pilot valve P-1. This sets up the machine for the application cycle.

V-9: Safety Valve: V-9 removes power (air) to the machine when the cover is opened.

P-1 Pilot Valve: P-1 controls the buff/cut sequence.

P-2 Pilot Valve: P-2 controls the feed sequence.

Cylinders

Safety Cylinder: A spring loaded cylinder that retains the feed assembly when the machine is in the rest position-power off.

Paddle Cylinder: A cylinder which is actuated at the beginning of the application cycle. It holds the box paddle beyond the actuation point of paddle valve V-2, to prevent additional actuation of the paddle valve before the application cycle ends.

Buff Cylinder: The buff cylinder controls the buff roller assembly the "L" clip of tape to the box corner.

Cut Cylinder: The cut cylinder controls the knife assembly that cuts the section of tape applied by the buff roller assembly.

Feed Cylinder: The feed cylinder controls the feed assembly that advances the tape and inserts it into the holding jaws immediately following the buff/cut sequence.

Jaw Cylinder: The jaw cylinder controls the holding jaws that retain the end of the tape between applications.

Air Flow Control Valves

F-1: Flow Control Valve 1 controls the extend rate of the feed cylinder. This is needed to prevent premature wear and damage to machine components.

F-2: Flow Control Valve 2 controls the retract rate of the feed cylinder. This is needed to prevent premature wear and damage to machine components.

F-3: Flow Control Valve 3 controls the retract rate of the buffing cylinder. This is needed to prevent premature wear and damage to machine components.

F-4: Flow Control Valve 4 controls the extend rate of the buffing cylinder. This is needed to ensure the tape is cut prior to being applied to the product.

7 - Operation

7.1 Tape Loading and Threading

The tape drum assembly is set up for dispensing 3/8 inch [9mm] or 1/2 inch [12mm] wide tape. For dispensing other tape widths refer to "Adjustments – Tape Width." A tape threading diagram is located outside the applicator on the top of the nest for quick reference.



WARNING

- **To reduce the risk associated with mechanical and pneumatic hazards:**
 - Read, understand and follow all safety and operating instructions before operating or servicing the case sealer
 - Allow only properly trained and qualified personnel to operate and/or service this equipment

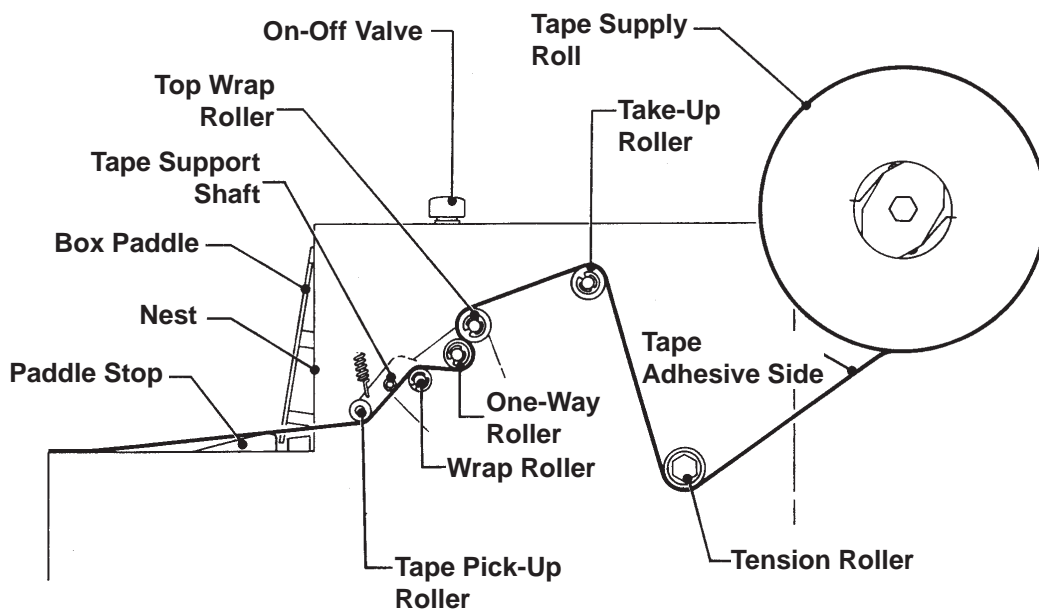

Figure 7-1 Tape Loading and Threading – Right Side View



WARNING

- **To reduce the risk associated with mechanical and pneumatic hazards:**
 - Never attempt to defeat the machine guard interlock
- **To reduce the risk associated with pinch and entanglement hazards:**
 - Turn air supply off and disconnect before performing any adjustments, maintenance or servicing the machine or taping heads

For easy access to tape loading and threading, open the cover located on the right side of the S-867. Release the cover latch, shown in **Figure 7-1**, pull outward on the upper part of the latch, unhook the latch and pivot open the cover.

Refer to **Figure 7-1** and thread the tape as follows:

1. Place the tape roll on the tape drum so the tape is dispensed downward, adhesive side forward. The tape roll must be fully against the drum flange.
2. Pull approximately 12 inches [300mm] of tape from the roll and thread the tape under the tension roller, adhesive side up.

7 - Operation (continued)

3. Bring the tape up over the take-up roller, adhesive side up.



WARNING

- **To reduce the risk associated with sharp blade hazards:**
 - Keep hands and fingers away from tape cutoff blades under orange blade guards. The blades are extremely sharp

4. Thread the tape over the top wrap roller, around the one way roller assembly, over the wrap roller, adhesive side toward the nest, begin tape down behind the tape holding roller and also the tape pick-up roll.

Note: To simplify the tape threading at the next reloading, replace with a new roll of "Scotch" brand filament tape, and splice the tape web together at the tension roller.

5. Pull out enough tape to tack it to the top of the nest as shown.

6. Close the cover and secure the latch.

Note: Remove all work tools, etc. from inside **S-867** case before closing cover.

7. Turn "On" (I) the main air supply at the on/off valve.
8. To clear the tape which has been tacked to the nest, manually holding the paddle stop down and push the box paddle in to cycle the unit. The applicator is ready to operate.



CAUTION

- **To reduce the risk associated with pinch and entanglement hazards:**
 - Keep hands, hair, loose clothing, and jewelry away from the opening in the nest

7.2 Operating Sequence

1. Move the box forward over the paddle stops, depressing the box paddle and hold it firmly and squarely against the nest vertical surface to apply the tape.



CAUTION

- **To reduce the risk associated with pinch and entanglement hazards:**
 - Always feed boxes into the machine by pushing only from the end of the box

2. The application only takes 1/4 second to apply the tape, then the box can be removed from the nest while the machine continues to complete the cycle.

 WARNING
<ul style="list-style-type: none"> • To reduce the risk associated with sharp blade hazards: <ul style="list-style-type: none"> - Keep hands and fingers away from tape cutoff blades under orange blade guards. The blades are extremely sharp

8.1 Tape Width

The tape drum is assembled at the factory for 3/8 inch [9mm] or 1/2 inch [12mm] wide tapes. For 5/8 inch [15mm] tapes the retainers must be moved to the secondary position on the tape drum. This is done by removing the two screws and relocating the retainer, then replacing and securing the screws.

8.2 Tape Web Alignment

The tape drum assembly controls tape web alignment in the applicator. Adjust the tape drum assembly so the tape web is dispensed, centered on the buffing rollers.

8.3 Tape Drum Tension

The tape drum assembly provides a preset tape roll tension to control over-travel. The tape drum tension requires no further adjustment.

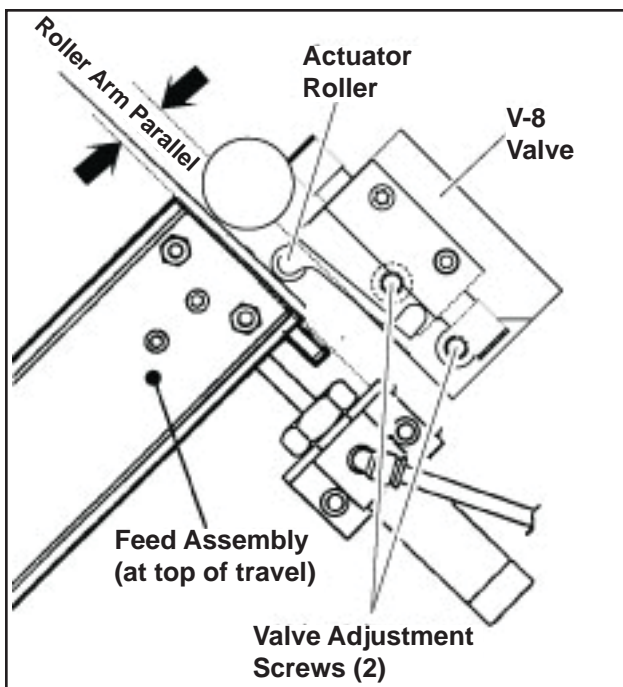

Figure 8-1 V-8 Valve Adjustment

8.4 Tape Tension Roller

The tension roller assembly, shown in **Figure 8-1**, provides a preset tension to the tape web. No further adjustment is required. If the tension roller assembly is replaced or comes out of adjustment, make adjustment as follows to obtain tension to the tape web: turn the lock nut, located behind the tension roller assembly, counterclockwise to increase tension, clockwise to decrease tension.

8.5 V-8 Valve Adjustment

The V-8 Valve is fully engaged (at the top of it's travel) and properly adjusted when the cam roller arm is in a parallel position to the valve body (see **Figure 8-1**). Loosen valve adjustment screws (2), slide valve up or down to obtain this adjustment and tighten screws. Be sure feed assembly is held at top of travel when making valve adjustment.

8.6 Air Flow Controls (Figure 8-2)

There are four air flow control valves on the **S-867**. Two each for the tape feed air cylinder and tape buff air cylinder. These are preset at the factory. Should adjustment be necessary, turn knob counterclockwise to increase cylinder speed and clockwise to decrease cylinder speed. The factory setting of each speed control valve is as follows: F1 - 1 turns open, F2 - 1-1/2 turns open, F3 - 1-1/2 turns open, F4 - 1-3/8 turns open.

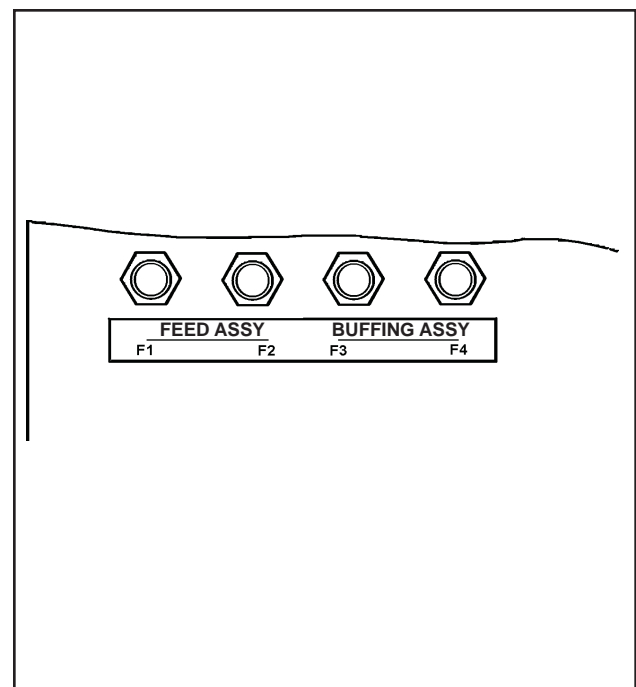

Figure 8-2 Air Flow Controls – Top View



WARNING

- To reduce the risk associated with pinch and entanglement hazards:
 - Turn air supply off and disconnect before performing any adjustments, maintenance or servicing the machine

9.1 Blade Replacement

Refer to Figure 9-1



WARNING

- To reduce the risk associated with sharp blade hazards:
 - Keep hands and fingers away from tape cutoff blades under orange blade guards. The blades are extremely sharp

1. Release latch and open cover on right side of S-867.
2. Remove and retain blade guard mounting screws (2), washers (2) and blade guard.
3. Wrap old blades cutting teeth with tape to prevent injury.

4. Remove and retain screws (2), washer (2), blade alignment retainer. Remove and discard old cutting blades (2).
5. Wrap tape around replacement cutting blades (2) teeth before installing.
6. Install blades as shown with beveled side of blade toward blade guard. Be sure blade is seated fully against blade alignment retainer and then tighten screws (2).
7. Remove tape from blades and replace blade guard (B) using screws (A) and plain washers (AA). Tighten screws.
8. Close and secure cover. Connect/turn on main air supply.

9.2 Air Line Filter

The air filter supplied with the S-867 is equipped with an automatic drain. No maintenance is required.

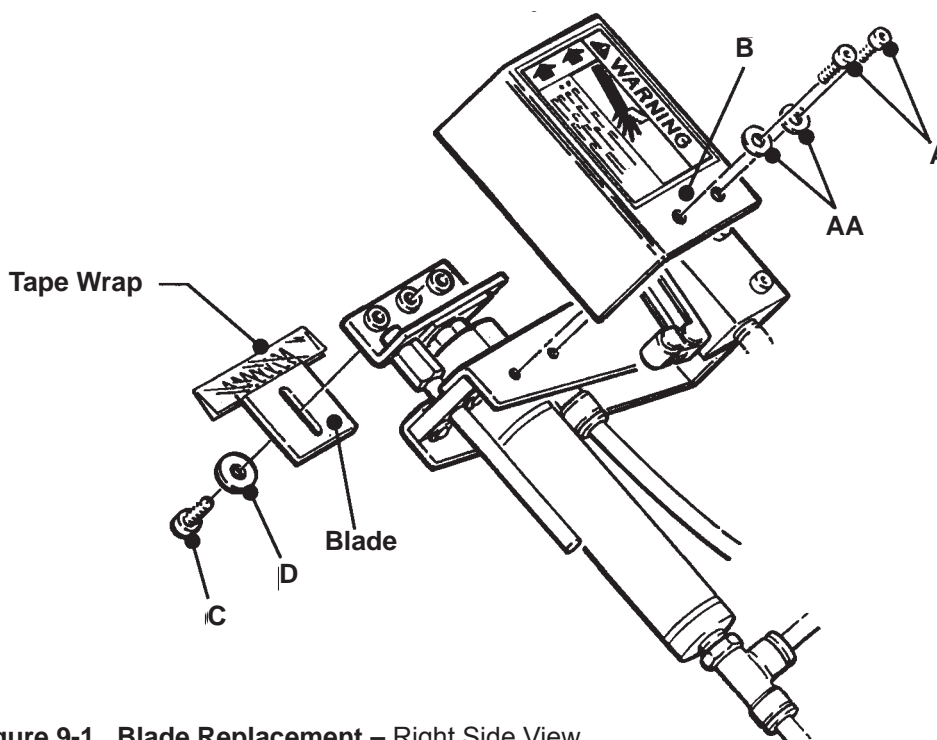

Figure 9-1 Blade Replacement – Right Side View

10 - Troubleshooting

10-1 Pneumatic Schematic

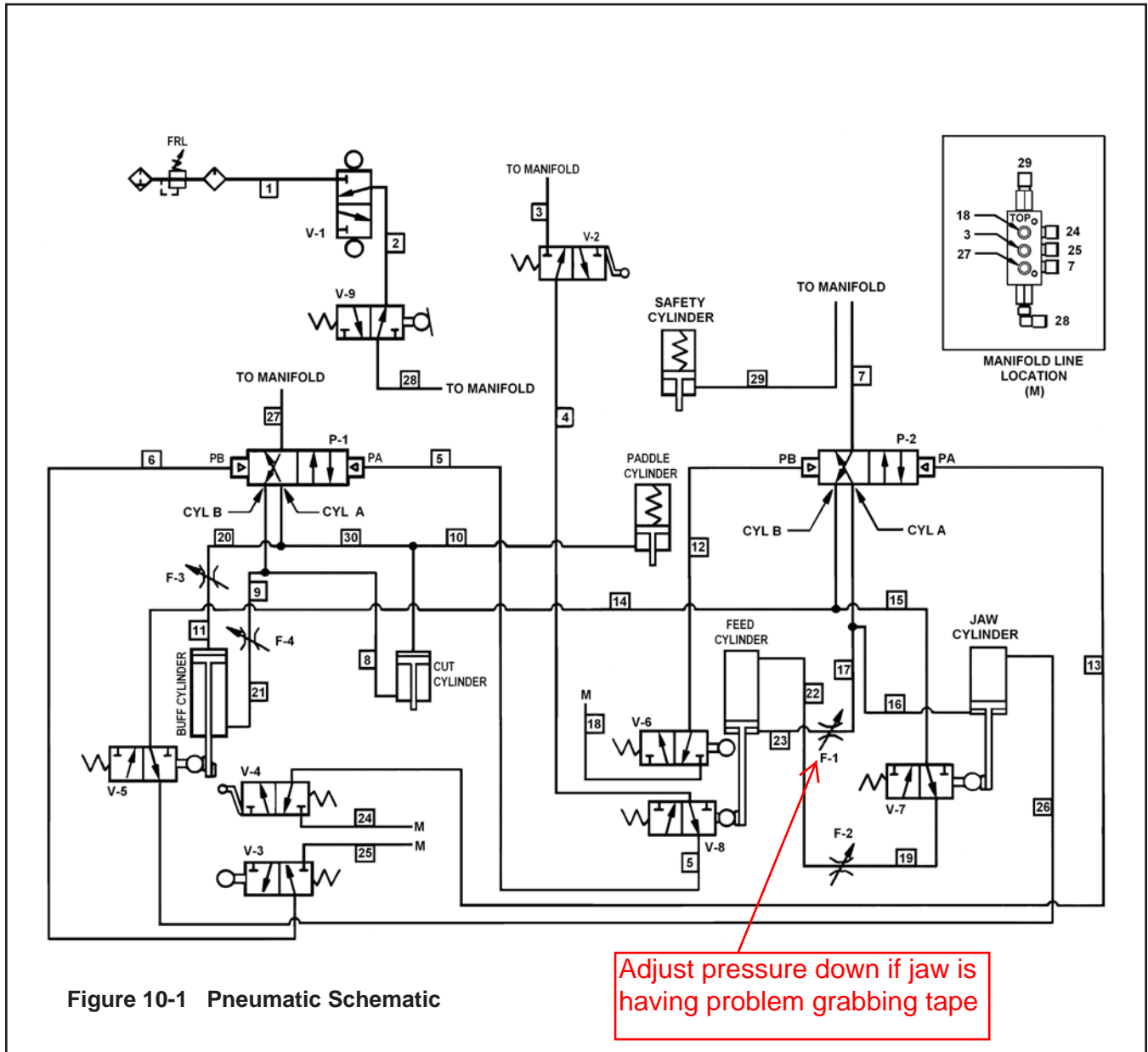

Figure 10-1 Pneumatic Schematic

Note: The complete pneumatic schematic is shown in the beginning of the Troubleshooting section, **Figure 10-1**.

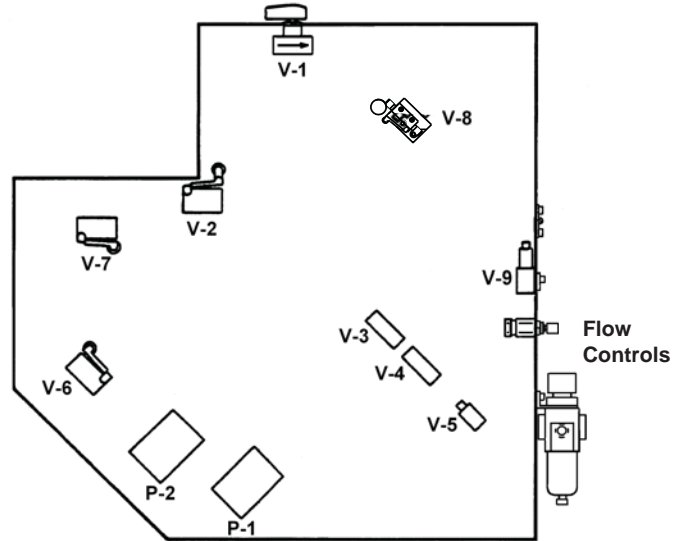

Figure 10-2 Troubleshooting Valve Locations – S-867 Right Side View

10-2 Troubleshooting Guide (arranged in sequence of machine operation)



WARNING

- **To reduce the risk associated with sharp blade hazards:**
 - Keep hands and fingers away from tape cutoff blades under orange blade guards. The blades are extremely sharp
- **To reduce the risk associated with mechanical and pneumatic hazards:**
 - Allow only properly trained and qualified personnel to operate and/or service this equipment
- **To reduce the risk associated with pinch and entanglement hazards:**
 - Turn air supply off and disconnect before performing any adjustments, maintenance or servicing the machine

Problem	Possible Cause	Correction
Unit does not cycle.	<ol style="list-style-type: none"> 1. Air supply shut off or not connected to unit. 2. Cover open. 3. Valve V-8 out of adjustment or defective. 4. Valve V-9 out of adjustment or defective. 5. Valve V-2 out of adjustment or defective. 6. Power valve P-1 defective. 7. Kinked air lines. 	<ol style="list-style-type: none"> 1. Check main air supply line and turn on unit. 2. Close cover. 3. Adjust or replace valve V-8. (see page 10) 4. Adjust or replace valve V-9. 5. Adjust or replace valve V-2. 6. Replace valve. 7. Straightened or replace air lines.
Cut-off assembly does not retract.	<ol style="list-style-type: none"> 1. Valve V-3 out of adjustment. 2. Cut-off assembly jammed with tape holding roller on tape feed assembly. 	<ol style="list-style-type: none"> 1. Adjust or replace valve V-3. 2. Turn off air and retract cut-off assembly. Actuate and hold V-3 valve and turn on air.
Buffing assembly does not retract.	<ol style="list-style-type: none"> 1. Valve V-3 out of adjustment or defective. 2. Flow control closed. 	<ol style="list-style-type: none"> 1. Adjust or replace valve V-3. 2. Adjust retract flow control for buff cylinder.



10-2 Troubleshooting Guide (arranged in sequence of machine operation)



WARNING

- **To reduce the risk associated with sharp blade hazards:**
 - Keep hands and fingers away from tape cutoff blades under orange blade guards. The blades are extremely sharp
- **To reduce the risk associated with mechanical and pneumatic hazards:**
 - Allow only properly trained and qualified personnel to operate and/or service this equipment
- **To reduce the risk associated with pinch and entanglement hazards:**
 - Turn air supply off and disconnect before performing any adjustments, maintenance or servicing the machine

Problem	Possible Cause	Correction
Cut-off assembly and buffing assembly cycle extend and retract and unit stops.	<ol style="list-style-type: none"> 1. Valve V-4 out of adjustment or defective. 2. Flow control closed. 3. Power valve P-2 defective. 	<ol style="list-style-type: none"> 1. Adjust or replace valve V-4. 2. Adjust extend flow control for feed cylinder. 3. Replace valve.
Buffing arm/cut-off blade out of sequence, oscillate back and forth.	<ol style="list-style-type: none"> 1. Valve V-3 out of adjustment or defective. 2. Valve V-2 out of adjustment or defective, sticks closed when box paddle is actuated. 	<ol style="list-style-type: none"> 1. Turn off air supply adjust valve V-3. Retract cut and buffing cylinder to retracted positions. Actuate and hold V-3 as air is turned on. This should put air circuitry in sequence. 2. Adjust or replace valve V-2.
Feed assembly retracts and stops.	<ol style="list-style-type: none"> 1. Valve V-6 out of adjustment or defective. 2. Valve V-5 out of adjustment or defective. 3. Power valve P-2 defective. 4. Valve V-7 out of adjustment or defective. 	<ol style="list-style-type: none"> 1. Adjust or replace valve V-6. 2. Adjust or replace valve V-5. 3. Replace valve. 4. Adjust or replace valve V-7.
Feed cylinder extends but does not actuate V-8 valve.	<ol style="list-style-type: none"> 1. Valve V-7 out of adjustment or defective. 2. Valve V-5 out of adjustment or defective. 3. Check for loose cylinder rod connection. 	<ol style="list-style-type: none"> 1. Adjust or replace valve V-7. 2. Adjust or replace valve V-5. 3. Retighten and adjust V-8 valve if needed.
Tape not cutting or tape end shredding or buffing rollers stop in mid-stroke and do not apply the tape.	<ol style="list-style-type: none"> 1. Dull blade. 2. Blade out of adjustment. 	<ol style="list-style-type: none"> 1. Replace blade. 2. Readjust blade and tighten screw.
Tape not being held by jaw assembly.	<ol style="list-style-type: none"> 1. Bad jaw roller. 2. Valve V-6 actuates before tape is in jaw assembly. 3. Valve V-7 actuated before tape is clamped. 4. Wave washer missing from tape holding roller 5. Jaws close too slow. 6. Feed cylinder extends too fast. 7. Low clamping force on tape. Missing or broken jaw spring 8. Bad one-way roller assembly. End of tape is not fed into the jaw assembly. 	<ol style="list-style-type: none"> 1. Replace roller. 2. Adjust V-6 valve. 3. Adjust or replace V-7 valve. 4. Replace wave washer. 5. Adjust jaw cylinder flow control. 6. Adjust flow control for extending feed cylinder. 7. Replace jaw spring. 8. Replace one-way roller assembly located on feed assembly.

10.3 Air Line Connections / Tubing Length

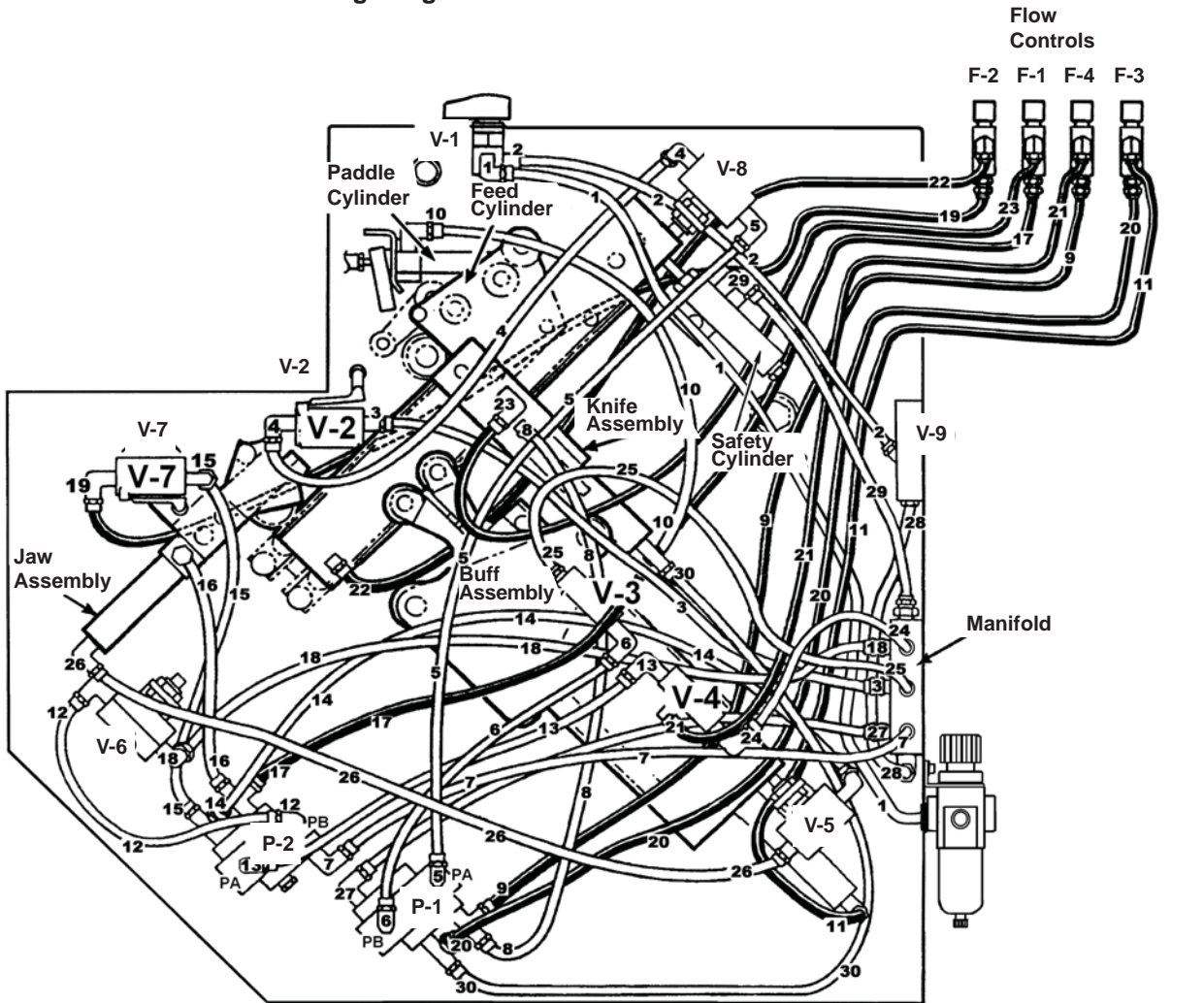

Air Line Number	From / To	Length	Air Line Number	From / To	Length
1	Air Regulator / V-1 Valve	927mm [36.5 inch]	16	P-2 Port A / Jaw Cyl. Rod	361mm [14.3 inch]
2	V-1 Valve / V-9 Valve	457mm [18.0 inch]	17	P-2 Port A / F1 End Port	488mm [19.2 inch]
3	Manifold / V-2 Valve	483mm [19.0 inch]	18	Manifold / V-6 Valve	635mm [25.0 inch]
4	V-2 Valve / V-8 Valve	439mm [17.3 inch]	19	V7 Valve / F2 End Port	787mm [31.0 inch]
5	V-8 Valve / P-1 Port PA	584mm [23.0 inch]	20	P-1 Port A / F3 End Port	610mm [24.0 inch]
6	V-3 Valve / P-1 Port PB	363mm [14.3 inch]	21	F4 Side Port / Buff Cyl.Rod	279mm [11.0 inch]
7	Manifold / P-2 Port B	546mm [21.5 inch]	22	F2 Side Port / Feed Cyl.Hd.	622mm [24.50 inch]
8	P1 Port A / Cut Cyl. Rod	533mm [21.0 inch]	23	F1 Side Port / Feed Cyl.Rod	521mm [20.5 inch]
9	P-1 Valve / F4 End Port	584mm [23.0 inch]	24	Manifold / V-4 Valve	305mm [12.0 inch]
10	Cut Cyl. Hd / Pad.Cyl.Rod	394mm [15.5 inch]	25	Manifold / V-3 Valve	622mm [24.5 inch]
11	F-3 End Port / Buff Cyl. Hd	229mm [9.0 inch]	26	V-5 Valve / Jaw Cyl. Head	673mm [26.5 inch]
12	V-6 Valve / P-2 Port PB	216mm [8.5 inch]	27	Manifold / P-1 Port IN	483mm [19.0 inch]
13	V-4 Valve/P-2 Port PA	241mm [9.5 inch]	28	Manifold / V-9 Valve	254mm [10.0 inch]
14	P-2 Port B / V-5 Valve	330mm [13.0 inch]	29	Manifold / Safety Cylinder	279mm [11.0 inch]
15	P-2 Port B / V-7 Valve	541 mm[21.3 inch]	30	P-1 Port A / Cut Cyl. Head	635 mm[25.0 inch]

Figure 10-3 Air Line Connections / Tubing Length

THIS PAGE IS BLANK

11 - Replacement Parts And Service Information

11.1 Recommended Spare Parts

It is suggested that the following spare parts be ordered and kept on hand:

Qty.	Part Number	Description
2	70-8601-0078-6	Blade – Serrated
4	78-8046-8594-5	Roller – Buffing

11.2 How To Order Replacement Parts

1. See **Figures 11-1 to 11-9**, in "Replacement Parts" section, to determine individual part and reference number.
2. Refer to the "Replacement Parts -- Illustrations and Parts Lists" section in this manual for part number and description.

Note – The complete description has been included for standard fasteners and some commercially available components. This has been done to allow obtaining these standard parts locally, should the customer elect to do so.

3. Refer to first page of this instruction manual "Replacement Parts and Service Information", for replacement parts ordering information.

Important – Not all the parts listed are normally stocked items. Some parts or assemblies shown are available only on a special order basis. Contact 3M/Tape Dispenser Parts to confirm item availability.

11.3 Repair Service

Refer to the first page of this instruction manual "Replacement Parts and Service Information" for information on repair service.

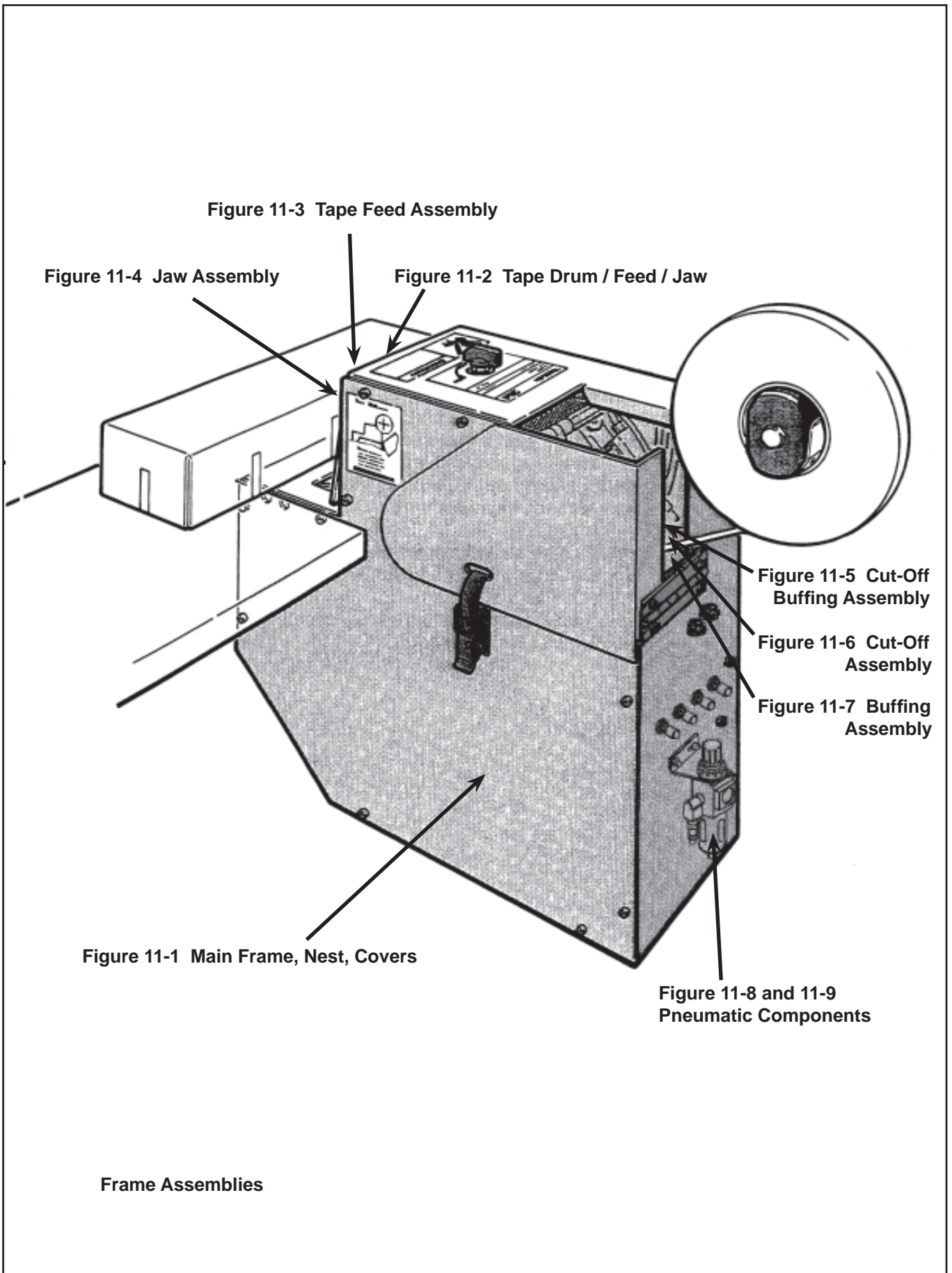

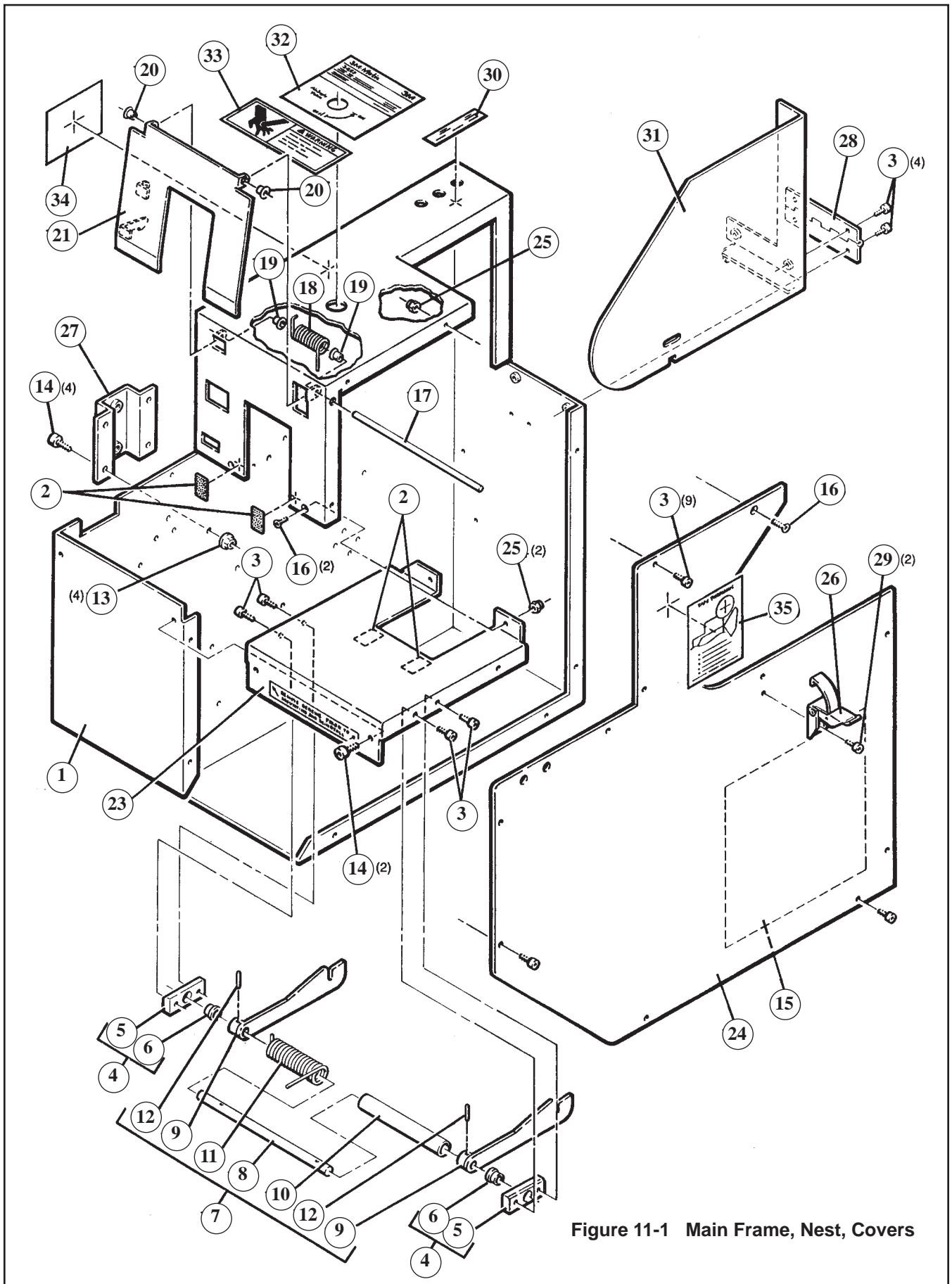

Figure 11-1 Main Frame, Nest, Covers

Figure 11-1

Ref. No.	3M Part No.	Description
11-1-1	78-8133-9642-7	Frame Weldment
11-1-2	78-8133-9649-2	Bumper
11-1-3	70-8000-0878-4	Screw – Soc Hd, Hex Soc Dr, 10-24 x 3/8 Lg.
11-1-4	78-8046-8599-4	Plate Assembly
11-1-5	78-8046-8600-0	Plate – Shaft
11-1-6	78-8161-4222-4	Bearing – Flanged, Oilite #FF-520-10
11-1-7	78-8098-8978-1	Paddle Assembly
11-1-8	78-8098-8975-7	Shaft – Paddle Stop
11-1-9	78-8098-8974-0	Stop – Paddle UH
11-1-10	78-8098-8976-5	Mandrel – Spring
11-1-11	78-8098-8973-2	Spring – Torsion
11-1-12	78-9260-8615-0	Pin – Slotted Spring, Med Duty, IJ8 Dia x 5/8 Lg
11-1-13	26-1002-4389-3	Nut – Flanged, Spiralock, 1/4-20
11-1-14	26-1006-1986-0	Screw – Soc Hd, Hex Soc Dr, 1/4-20 x 3/4 Lg.
11-1-15	78-8133-9648-4	Label – Valve
11-1-16	26-1006-1984-5	Screw – Flt Hd, Hex Soc Dr, Loc-Wel, 8-32 x 1/2 Lg.
11-1-17	78-8059-5753-3	Shaft – Paddle
11-1-18	78-8046-8510-1	Spring – Paddle
11-1-19	78-8161-8389-7	Bearing – Nyliner, Thomson #4L1-FF
11-1-20	78-8002-4778-1	Bearing – Nyliner, Thomson #4L2-FF
11-1-21	78-8052-6250-4	Paddle – Box
11-1-23	78-8098-9003-7	Nest Assembly
11-1-24	78-8059-5756-6	Cover
11-1-25	26-1006-2447-2	Nut – S-Lock, Nylon Insert, 8-32
11-1-26	26-1006-2066-0	Latch – Over Center Draw, Southco #97-50-110-15
11-1-27	78-8052-6257-9	Bracket – Mount, R/H
11-1-28	78-8059-5746-7	Hinge – Cover
11-1-29	70-8656-5934-9	Screw – Soc Hd, Hex Soc Dr, 8-32 x 1/4 Lg.
11-1-30	78-8133-9643-5	Label – Flow Control
11-1-31	78-8059-5741-8	Cover – Safety
11-1-32	78-8133-9656-7	Label – Information
11-1-33	78-8119-6594-2	Label – Warning, Sharp Knife/Rollers
11-1-34	78-8119-6596-7	Label – Safety Instructions, Air Supply
11-1-35	78-8119-6598-3	Label – Tape Threading

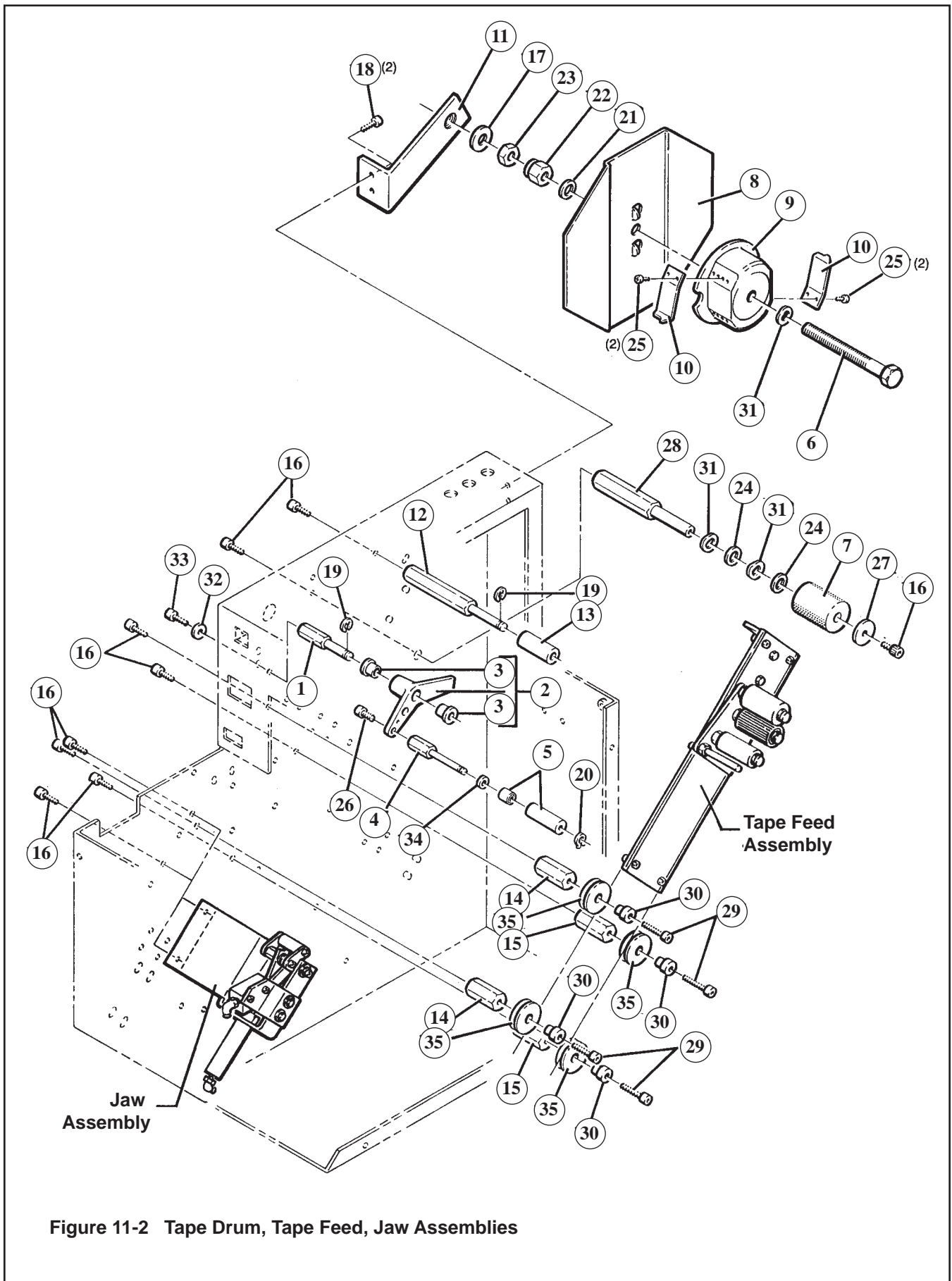

Figure 11-2 Tape Drum, Tape Feed, Jaw Assemblies

Figure 11-2

Ref. No.	3M Part No.	Description
11-2-1	78-8046-8542-4	Shaft – Tape Arm
11-2-2	78-8046-8511-9	Tape Arm Assembly (Pickup)
11-2-3	78-8161-4227-3	Bearing – Flange, Oilite #FF-520-5
11-2-4	78-8052-6371-8	Shaft – Pickup
11-2-5	78-8046-8545-7	Pickup Roller Assembly
11-2-6	78-8059-5754-1	Bolt – Modified
11-2-7	78-8052-6334-6	Roller – Tension
11-2-8	78-8046-8549-9	Plate – Tape Backup
11-2-9	78-8023-2190-7	Drum – Tape
11-2-10	78-8023-2191-5	Retainer – Tape
11-2-11	78-8059-5772-3	Support – Tape Drum
11-2-12	78-8046-8551-5	Shaft – Roller (Take-up)
11-2-13	78-8046-8562-2	Roller – Top Wrap
11-2-14	78-8059-5781-4	Standoff – Wheel
11-2-15	78-8059-5755-8	Standoff – Wheel (Eccentric)
11-2-16	70-8656-5938-0	Screw – Soc Hd Hex Soc Dr, 1/4-20 x 1/2 Lg.
11-2-17	70-8000-5377-2	Washer – Plain, Type A, 1/2
11-2-18	26-1006-1770-8	Screw – Soc Hd, Hex Soc Dr, 10-24 x 1/2 Lg.
11-2-19	78-8656-4003-7	Ring – Retaining E-Ring, Waldes #5133-37
11-2-20	78-8656-5004-4	Ring – Retaining Grip Ring, Waldes #5555-25
11-2-21	78-8014-1001-6	Bearing – Thrust, Oilite #TT-706
11-2-22	26-1001-2646-0	Nut – Nyl Insert, 1/2-13
11-2-23	70-8000-5374-9	Nut – Jam, 1/2-13
11-2-24	26-1000-0664-7	Washer – Shim, .50 ID x .75 OD x .015 Thk
11-2-25	26-1002-4949-4	Screw – Self Tap, Thrd Form, Plastite #6-19 x 3/8 Lg.
11-2-26	26-1006-1986-0	Screw – Soc Hd, Hex Soc Dr, 1/4-20 x 3/4 Lg.
11-2-27	26-1002-8745-2	Washer – Plain, Type B, .28 ID x 1.0 OD x .06 Th
11-2-28	78-8052-6390-8	Shaft – Tension
11-2-29	26-1006-1981-1	Screw – Soc Hd, Hex Soc Dr, 1/4-20 x 1-1/4 Lg.
11-2-30	26-1004-1508-7	Bushing – Adapter, Stationary, Dua-L-Vee, Bishop-Wisecarver#B-2
11-2-31	26-1002-6708-2	Washer – U-Bent, Assoc. Sp #U500-0170
11-2-32	26-1009-3643-9	Washer – Plain, 9/32 ID x 5/8 OD x 1/8 Thk
11-2-33	70-8000-2641-4	Screw – Soc Hd, Hex Soc Dr, 1/4-20 x 5/8 Lg.
11-2-34	78-8163-0100-2	Bearing – Thrust, Oilite #TT-504
11-2-35	26-1004-1506-1	Wheel-Guide – Dua-L-Vee Bishop-Wisecarver#W2X

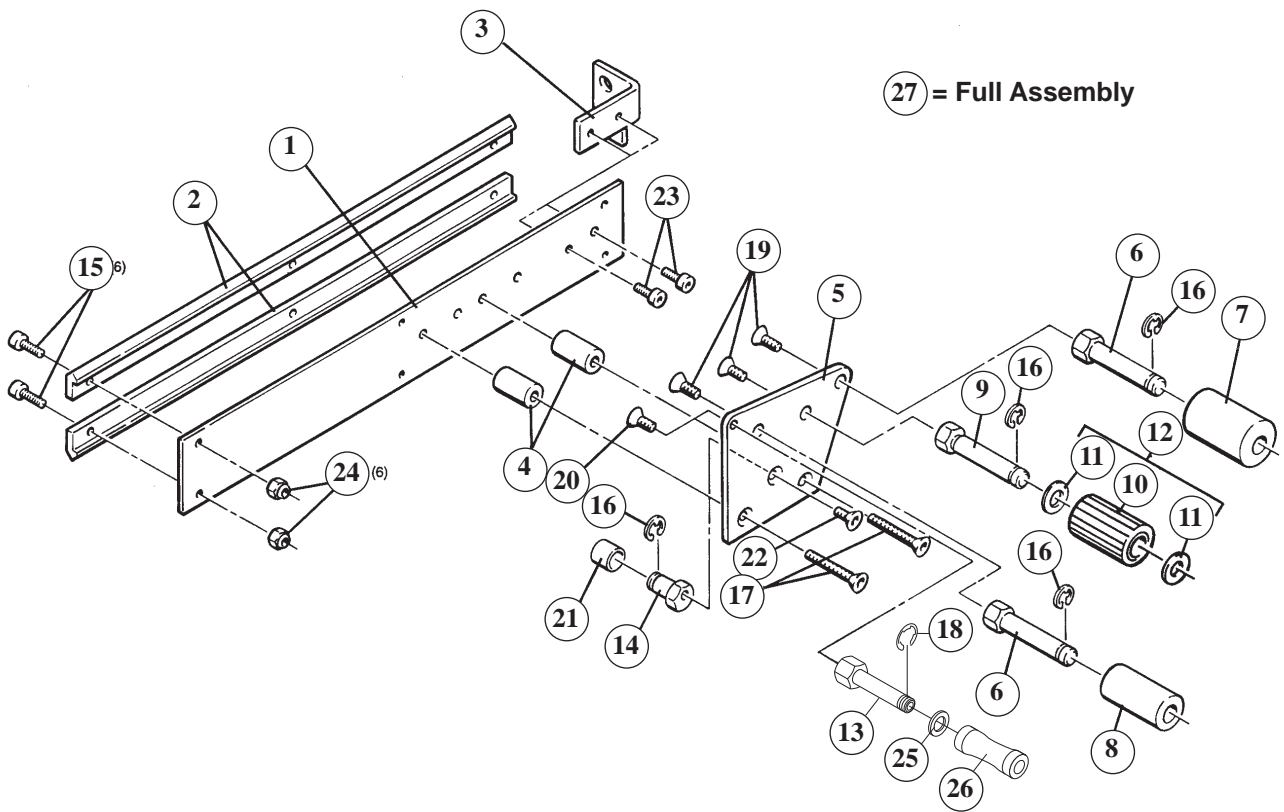

Figure 11-3 Tape Feed Assembly

S867**Figure 11-3**

Ref. No.	3M Part No.	Description
11-3-1	78-8052-6349-4	Plate – Stripper
11-3-2	78-8059-5758-2	Rail – Stripper
11-3-3	78-8052-6350-2	Bracket – Stripper Cylinder
11-3-4	78-8046-8559-8	Spacer – Stripper
11-3-5	78-8046-8560-6	Plate – Stripper (Tape)
11-3-7	78-8046-8562-2	Roller – Top Wrap
11-3-8	78-8046-8563-0	Roller – Wrap
11-3-9	78-8046-8564-8	Shaft – Roller (Clutch)
11-3-10	78-8059-5779-8	Roller Assembly – One-Way
11-3-11	78-8163-0109-3	Bearing – Thrust, Oilite #TT-703
11-3-12	78-8059-5778-0	Roller Assembly Kit – One-Way (Includes Ref No. 29 and (2) Ref No. 30)
11-3-13	78-8046-8567-1	Shaft – Concave Roller
11-3-14	78-8046-8569-7	Cam – Hex
11-3-15	26-1004-6031-5	Screw – Soc Hd, Hex Soc Dr, 10-24 x 1/2 Lg.
11-3-16	78-8656-4003-7	Ring – Retaining E-Ring, Waldes #5133-37
11-3-17	26-1006-2403-5	Screw – Flt Hd, Hex Soc Dr, 10-24 x 1-1/2 Lg.
11-3-18	78-8656-5004-4	Ring - Retaining Grip Ring - Waldes #5555-25
11-3-19	70-7023-8090-1	Screw – Flt Hd, Hex Soc Dr, 1/4-20 x 1/2 Lg.
11-3-20	70-8000-1289-3	Screw – Flt Hd, Hex Soc Dr, 8-32 x 1/2 Lg.
11-3-21	78-8046-8570-5	Bumper – Cam
11-3-22	26-1002-2124-6	Screw – Flt Hd, Hex Soc Dr, 10-24 x 1/2 Lg.
11-3-23	26-1006-1333-5	Screw – Soc Hd, Hex Soc Dr, 10-24 x 3/8 Lg.
11-3-24	26-1004-5847-5	Nut – Nyl Insert, S-Lock, 10x24
11-3-25	26-1000-0922-9	Washer - Wave 1/4"
11-3-26	78-8068-3913-6	Roller - Concave
11-3-27	78-8111-1289-1	Full Assembly

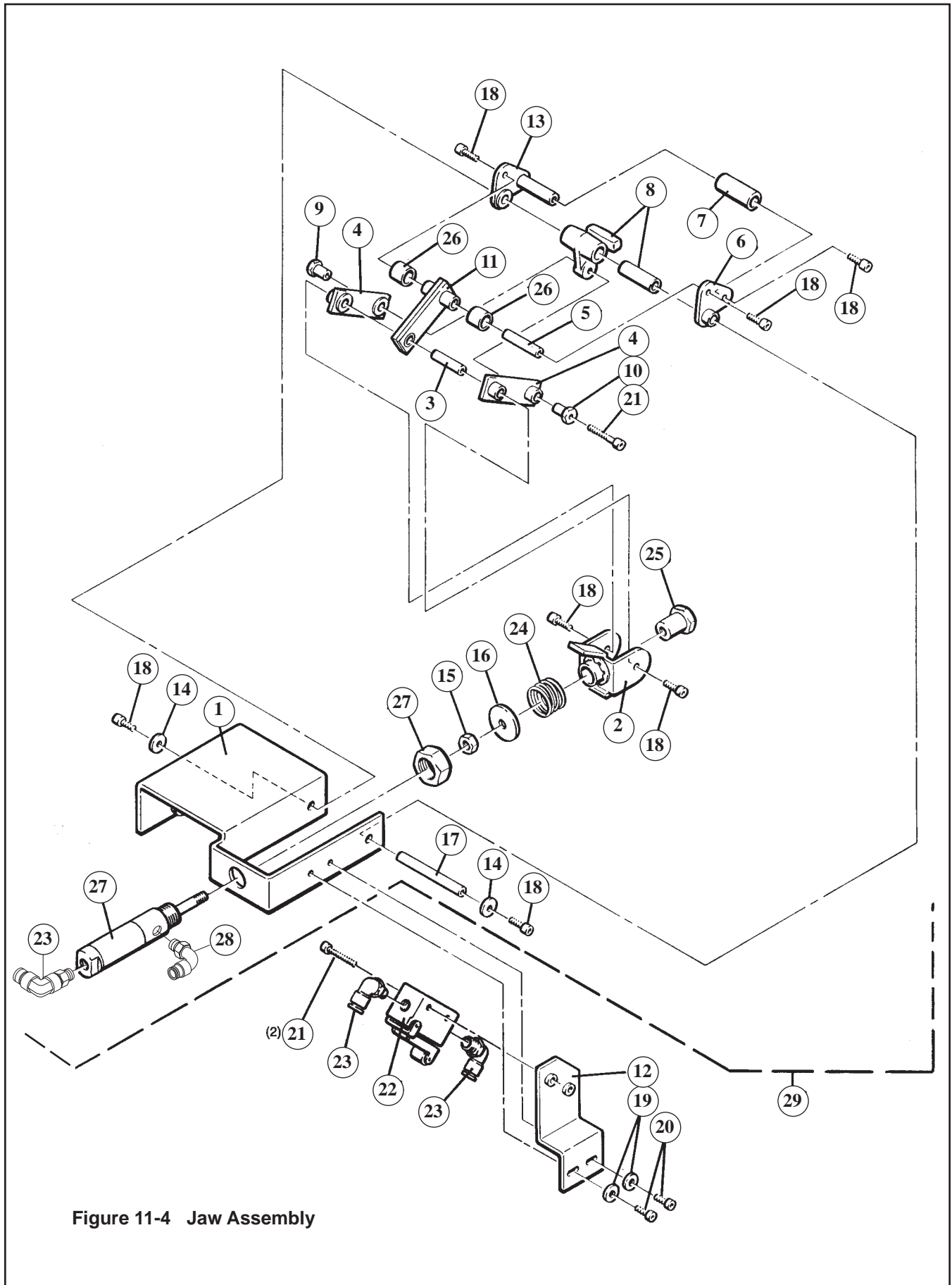

Figure 11-4 Jaw Assembly

Figure 11-4

Ref. No.	3M Part No.	Description
11-4-1	78-8054-8685-5	Bracket – Jaw Mounting
11-4-2	78-8054-8687-1	Clevis – Air Cylinder
11-4-3	78-8054-8671-5	Shaft – Clevis
11-4-4	78-8054-8672-3	Jaw Link Assembly – Outer
11-4-5	78-8054-8673-1	Shaft – Link
11-4-6	78-8054-8680-6	Roller Plate Assembly – R/H
11-4-7	78-8054-8683-0	Roller – Jaws
11-4-8	78-8054-8684-8	Tape Clamp Assembly
11-4-9	78-8054-8674-9	Pin – Link Tap
11-4-10	78-8054-8675-6	Pin – Link Thru
11-4-11	78-8054-8676-4	Jaw – Link Assembly - Inner
11-4-12	78-8046-8541-6	Bracket – Valve
11-4-13	78-8079-5487-6	Roller Plate Assembly – L/H
11-4-14	12-7991-1737-4	Washer – Plain, Type A, #8
11-4-15	26-1004-0331-5	Nut – Jam, 5/16 - 24
11-4-16	26-1003-3708-3	Washer – Plain, .328 ID x 1.25 OD x .063 Thk
11-4-17	78-8054-8677-2	Shaft – Jaws
11-4-18	70-8000-0864-4	Screw – Soc Hd, Hex Soc Dr, 8-32 x 1/2 Lg.
11-4-19	26-1000-4442-4	Washer – Type A, #10
11-4-20	26-1006-1333-5	Screw – Soc Hd, Hex Soc Dr, 10-24 x 3/8 Lg.
11-4-21	70-8000-2155-5	Screw – Soc Hd, Hex Soc Dr, 8-32 x 1 Lg.
11-4-22	26-1000-0922-9	Washer – Wave 1/4" ← 26-1004-7410-0 Air 3 Way Roller Actr.
11-4-23	26-1016-2163-4	Fitting - Elbow, 1/4 Tube x 1/4 NPT SMC Corp KQ2L07-35S
11-4-24	78-8054-8691-3	Spring – Jaw
11-4-25	78-8111-1279-2	Adapter – Air Cylinder
11-4-26	78-8054-8719-2	Spacer
11-4-27	26-1016-2151-9	Cylinder – Jaw, SMC Corp #NCMB106-0062C
11-4-28	26-1016-2161-8	Fitting - Male Run Tee 1/4 Tube x 1/4 Tube x 1/8 Male NPT, SMC Corp #KJY07-34S
11-4-29	78-8111-1282-6	Jaw Assembly (Replacement)

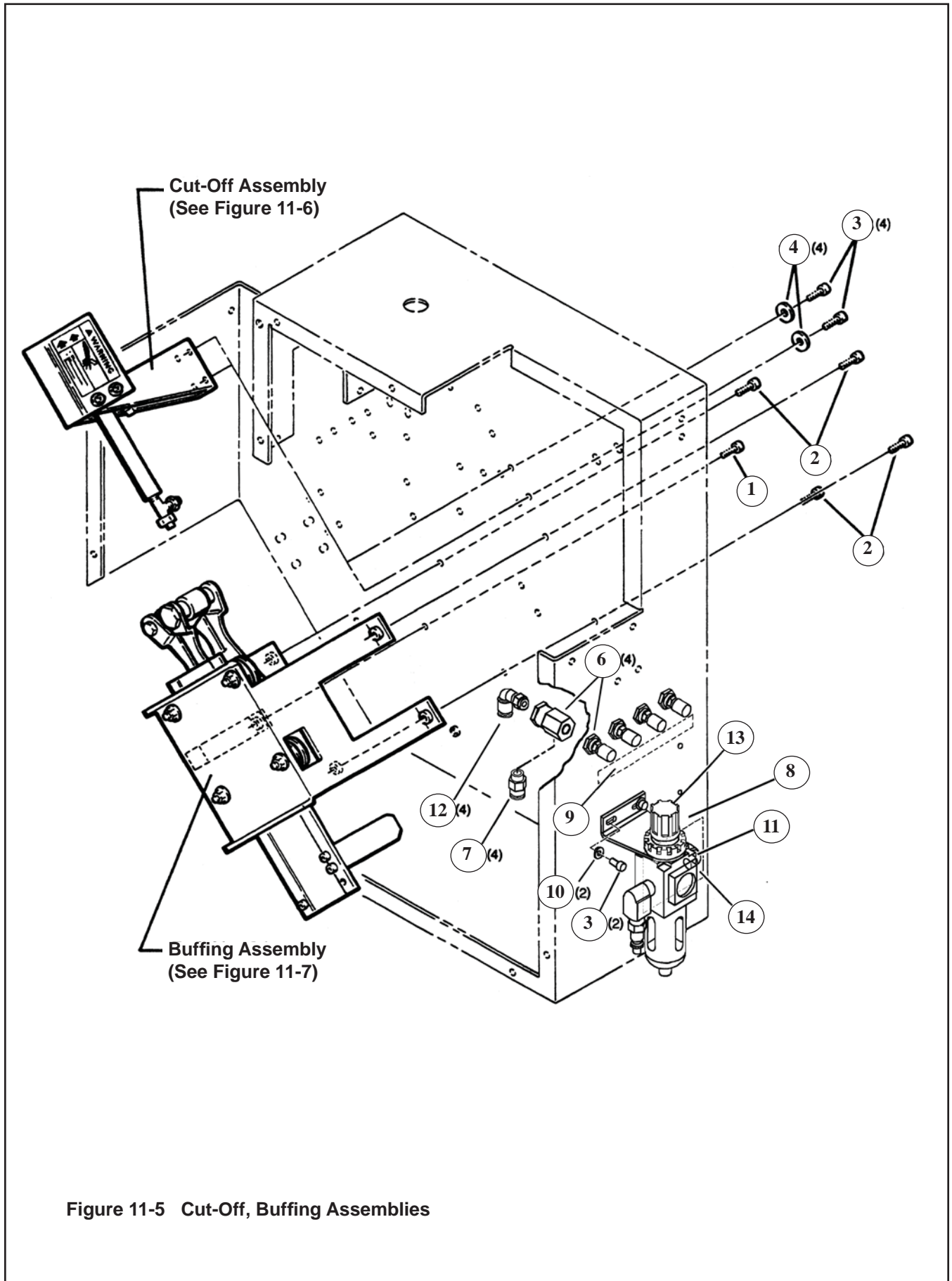

Figure 11-5 Cut-Off, Buffing Assemblies

S867

Figure 11-5

Ref. No.	3M Part No.	Description
11-5-1	70-8000-0878-4	Screw – Soc Hd, Hex Soc Dr, 10-24 x 3/8 Lg
11-5-2	70-8656-5938-0	Screw – Soc Hd Hex Soc Dr, 1/4-20 x 1/2 Lg.
11-5-3	26-1006-1770-8	Screw – Soc Hd, Hex Soc Dr, 10-24 x 1 /2 Lg.
11-5-4	26-1007-3472-7	Washer – Plain, Hardened, 13/64 ID x 1/2 OD
11-5-6	26-1004-7415-9	Flow Control – Flairline #RFC-1/8 PK ← 78-8137-9106-4
11-5-7	26-1016-2159-2	Fitting – Male Connector, 1/4 O.D. Tube x 1/8 Male NPT, SMC Corp #KJH07-34S
11-5-8	78-8003-8731-4	Bushing – Snap, Heyco #2096
11-5-9	78-8133-9643-5	Label – Flow Control
11-5-10	26-1000-4442-4	Washer – Type A, #10
11-5-11	26-1016-2163-4	Fitting - Elbow, 1/4 Tube x 1/4 NPT SMC Corp KQ2L07-35S
11-5-12	26-1016-2160-0	Fitting - Elbow, 1/4 Tube x 1/8 NPT SMC Corp KJL07-34S ← 26-1001-7170-6
11-5-13	26-1016-2155-0	Filter/Regulator (Includes mounting bracket)
11-5-14	78-8119-6596-7	Label – Safety Instructions, Air Supply

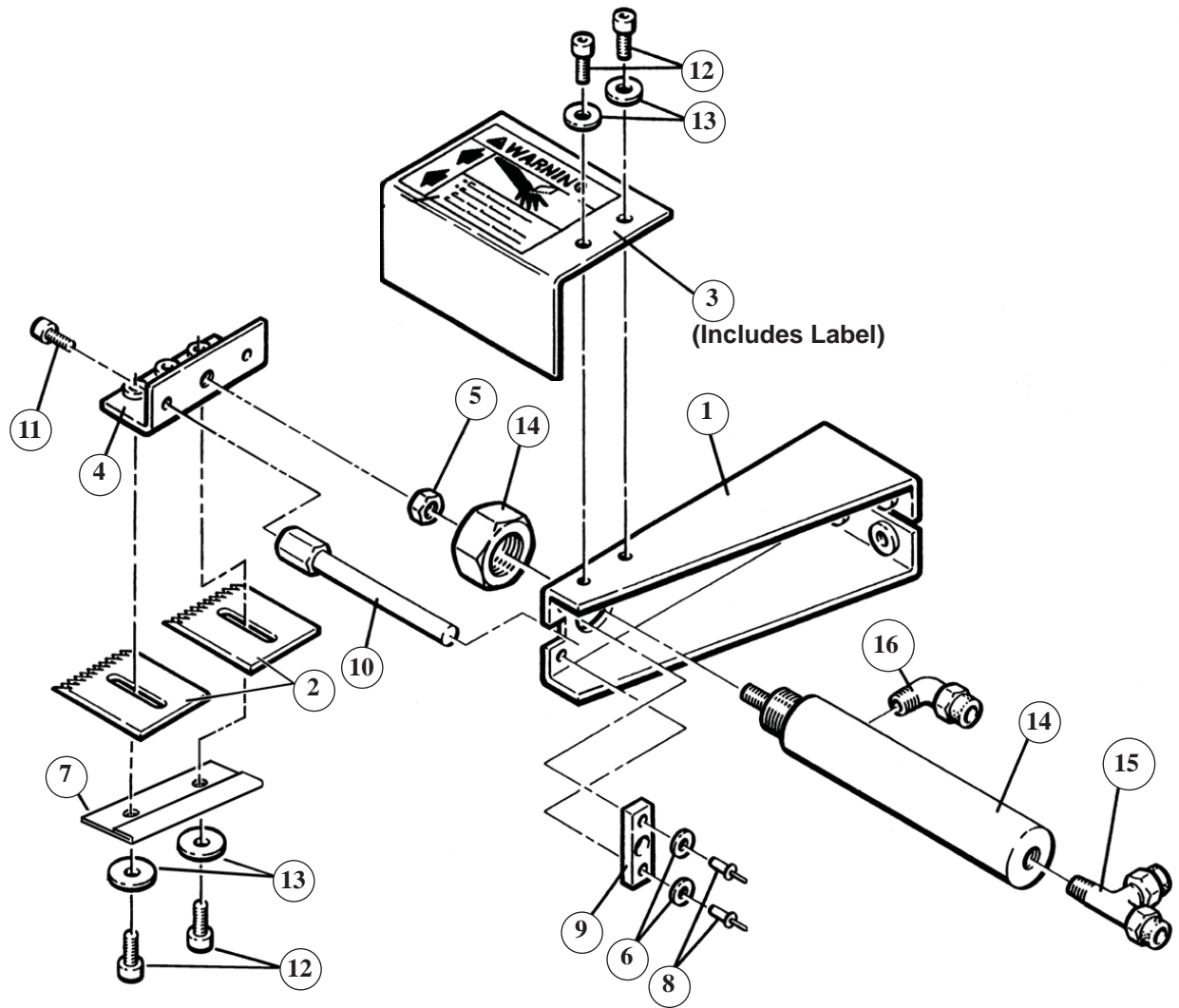

Figure 11-6 Cut-Off Assembly

Figure 11-6

Ref. No.	3M Part No.	Description
11-6-1	78-8046-8572-1	Bracket – Air Cylinder
11-6-2	70-8601-0078-6	Blade
11-6-3	78-8046-8575-4	Blade Guard Assembly
11-6-4	78-8079-5480-1	Bracket – Blade Mounting
11-6-5	26-1000-8448-7	Nut – Jam, 1/4-28
11-6-6	12-7991-1735-8	Washer – Plain, Type A, #4
11-6-7	78-8068-3916-9	Clamp - Blade
11-6-8	78-8005-2959-2	Rivet – Pop, 1 /8 Dia, USM #AD-45-ABS
11-6-9	78-8046-8577-0	Bracket – Slide
11-6-10	78-8046-8578-8	Rod – Slide
11-6-11	70-8000-0864-4	Screw – Soc Hd, Hex Soc Dr, 8-32 x 1/2 Lg.
11-6-12	26-1006-1333-5	Screw – Soc Hd, Hex Soc Dr, 10-24 x 3/8 Lg.
11-6-13	26-1000-4442-4	Washer – Plain, Type A, #10
11-6-14	26-1016-2152-7	Cylinder – Cut, SMC Corp. #NCMB075-0200C
11-6-15	26-1016-2161-8	Fitting - Male Run Tee 1/4 Tube x 1/4 Tube x 1/8 Male NPT, SMC Corp #KJY07-34S
11-6-16	26-1016-2160-0	Fitting - Elbow, 1/4 Tube x 1/8 NPT SMC Corp KJL07-34S

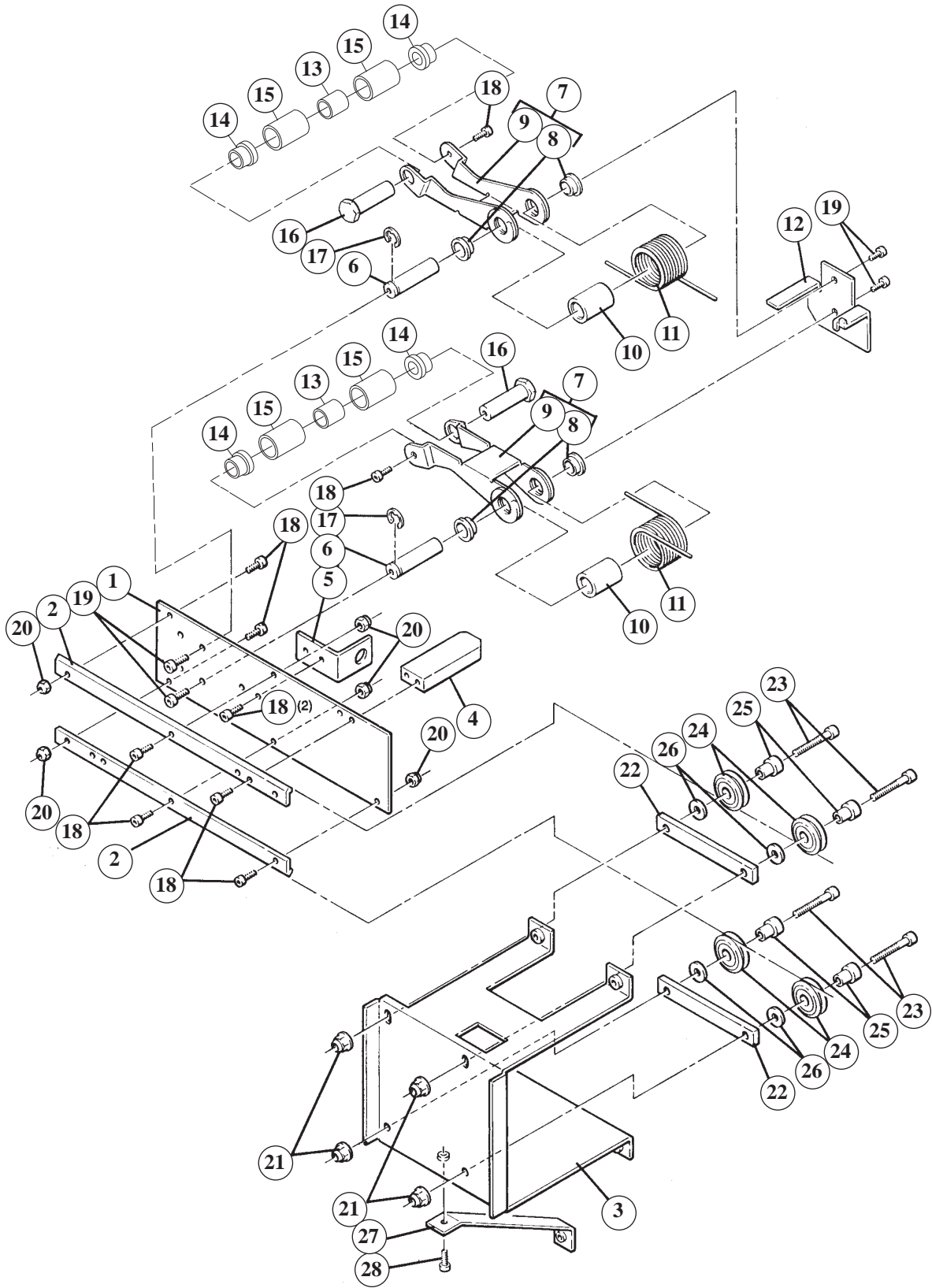

Figure 11-7 Buffing Assembly

Figure 11-7

Ref. No.	3M Part No.	Description
11-7-1	78-8052-6366-8	Plate – Arm Mounting
11-7-2	78-8059-5734-3	Rail – Buffing
11-7-3	78-8059-5735-0	Bracket – Mounting
11-7-4	78-8052-6369-2	Cam – Switch
11-7-5	78-8046-8585-3	Bracket – Cylinder
11-7-6	78-8046-8586-1	Shaft – Buffing Arm
11-7-7	78-8046-8587-9	Buffing Arm Assembly
11-7-8	78-8032-1206-3	Bearing – Flanged, Oilite #FF-636-3
11-7-9	78-8046-8588-7	Arm– Buffing ← 78-8046-8587-9
11-7-10	78-8046-8589-5	Mandrel – Spring
11-7-11	78-8046-8590-3	Spring – Buffing Roller
11-7-12	78-8046-8591-1	Plate – Buff Mounting
11-7-13	78-8046-8592-9	Sleeve – Buffing Roller
11-7-14	78-8046-8593-7	Spacer – Buffing Roller
11-7-15	78-8046-8594-5	Roller – Buffing
11-7-16	78-8046-8595-2	Shaft – Buffing
11-7-17	78-8656-4012-8	Ring – Retaining E-Ring, Waldes #5133-50
11-7-18	26-1006-1770-8	Screw – Soc Hd, Hex Soc Dr, 10-24 x 1/2 Lg.
11-7-19	70-8656-5938-0	Screw – Soc Hd, Hex Soc Dr, 1/4-20 x 1/2 Lg.
11-7-20	18-1755-2103-0	Nut – Nylon Insert, 10-24
11-7-21	26-1002-4389-3	Nut – Flanged, Spiralock, 1/4-20
11-7-22	78-8052-6367-6	Spacer – Roller
11-7-23	70-8000-1495-6	Screw – Soc Hd, Hex Soc Dr, 1/4-20 x 1-1/2 Lg.
11-7-24	26-1004-1506-1	Wheel – Guide, Dua-L-Vee #W2X
11-7-25	26-1004-1508-7	Bushing – Adapter, Stationary, Dua-L-Vee #B-2
11-7-26	26-1006-1771-6	Washer – Plain, SST, H.K. Metalcraft, #18-8
11-7-27	78-8059-5763-2	Brace – Buffing Assembly
11-7-28	70-8000-0878-4	Screw – Soc Hd, Hex Soc Dr, 10-24 x 3/8 Lg.

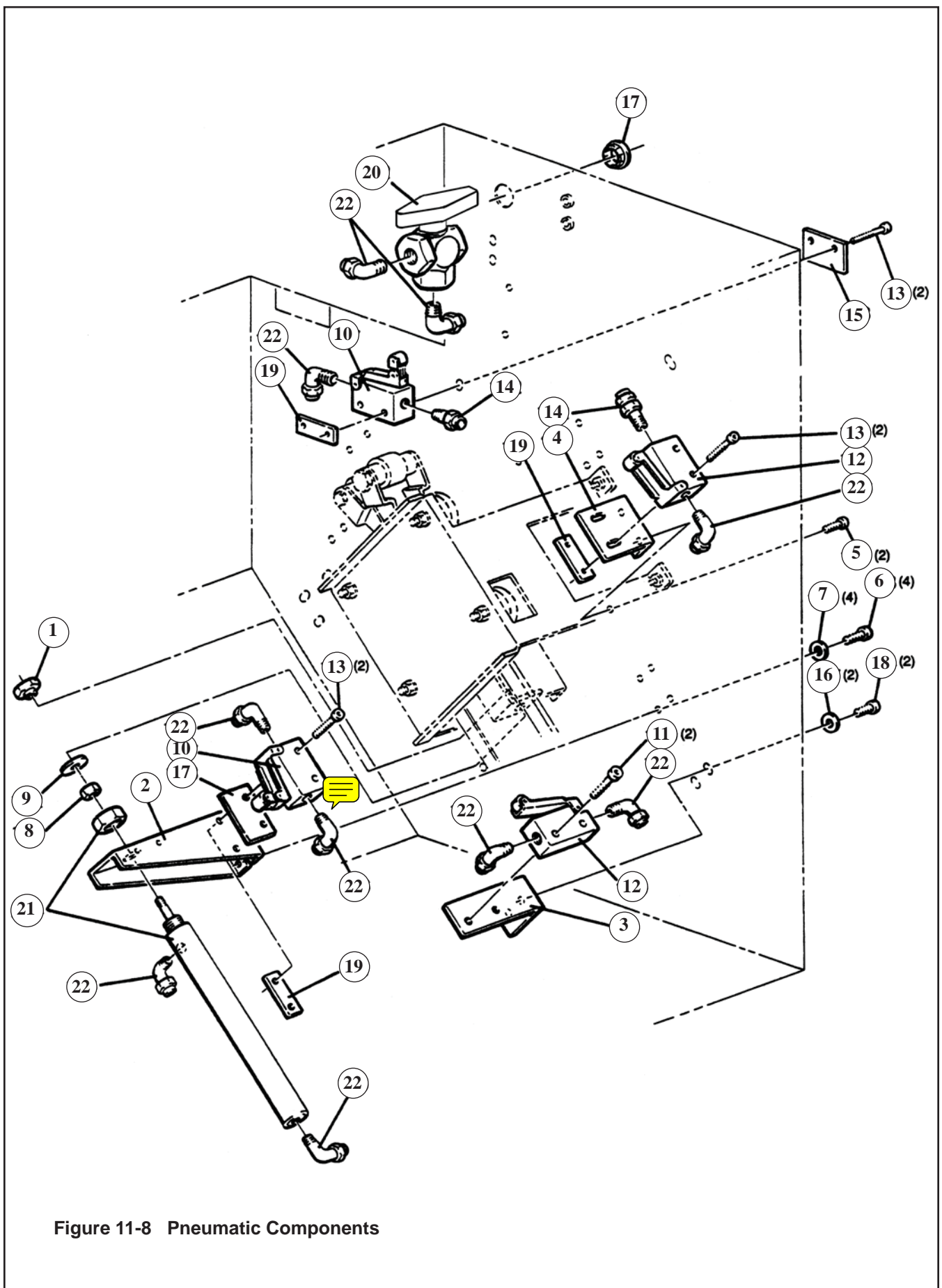

Figure 11-8 Pneumatic Components

Figure 11-8

Ref. No.	3M Part No.	Description
11-8-1	78-8046-8553-1	Mount – Cylinder Rod
11-8-2	78-8046-8572-1	Bracket – Air Cylinder
11-8-3	78-8052-6341-1	Mount – Valve V-5
11-8-4	78-8046-8597-8	Bracket – Switch
11-8-5	70-8656-5938-0	Screw – Soc Hd Hex Soc Dr, 1/4-20 x 1/2 Lg.
11-8-6	26-1006-1770-8	Screw – Soc Hd, Hex Soc Dr, 10-24 x 1/2 Lg.
11-8-7	26-1007-3472-7	Washer – Plain, Hardened, 13/64 ID x 1/2 OD
11-8-8	26-1000-8448-7	Nut – Jam, 1/4-28
11-8-9	26-1002-8745-2	Washer – Plain, Type B, .28 ID x 1.0 OD x .06 Th
11-8-10	26-1004-7411-8	Valve – Air, Internal Check Valve, One-Way Roller 1/8 NPT Ports, SMC #NVM-131-NO1-02-X6
11-8-11	70-8000-2155-5	Screw – Soc Hd, Hex Soc Dr, 8-32 x 1 Lg.
11-8-12	26-1004-7410-0	Valve – Air, 3-Way, Roller Actuator, SMC #VM 131 -N01 -01
11-8-13	26-1006-1985-2	Screw – Soc Hd, Hex Soc Dr, 8-32 x 1-1/4 Lg.
11-8-14	26-1016-2159-2	Fitting – Male Connector, 1/4 O.D. Tube x 1/8 Male NPT, SMC Corp #KJH07-34S
11-8-15	78-8079-5483-5	Spacer – Valve, V-4
11-8-16	26-1002-6708-2	Washer – U-Bent, Assoc. Sp #U500-0170
11-8-17	78-8003-8731-4	Bushing – Snap, Heyco #2096
11-8-18	70-8000-2641-4	Screw – Soc Hd, Hex Soc Dr, 1/4-20 x 5/8 Lg.
11-8-19	26-1005-5133-7	Nut Plate – Ohio #TP1416
11-8-20	26-1005-5410-9	Valve – 3-Way, Brass Ball, Manual Actuator, 1/8 NPTF, SMC #701-2F2F2F-BT
11-8-21	26-1016-2147-7	Cylinder – Buffing, SMC Corp #NCMB075-0512C
11-8-22	26-1016-2160-0	Fitting - Elbow, 1/4 Tube x 1/8 NPT SMC Corp KJL07-34S

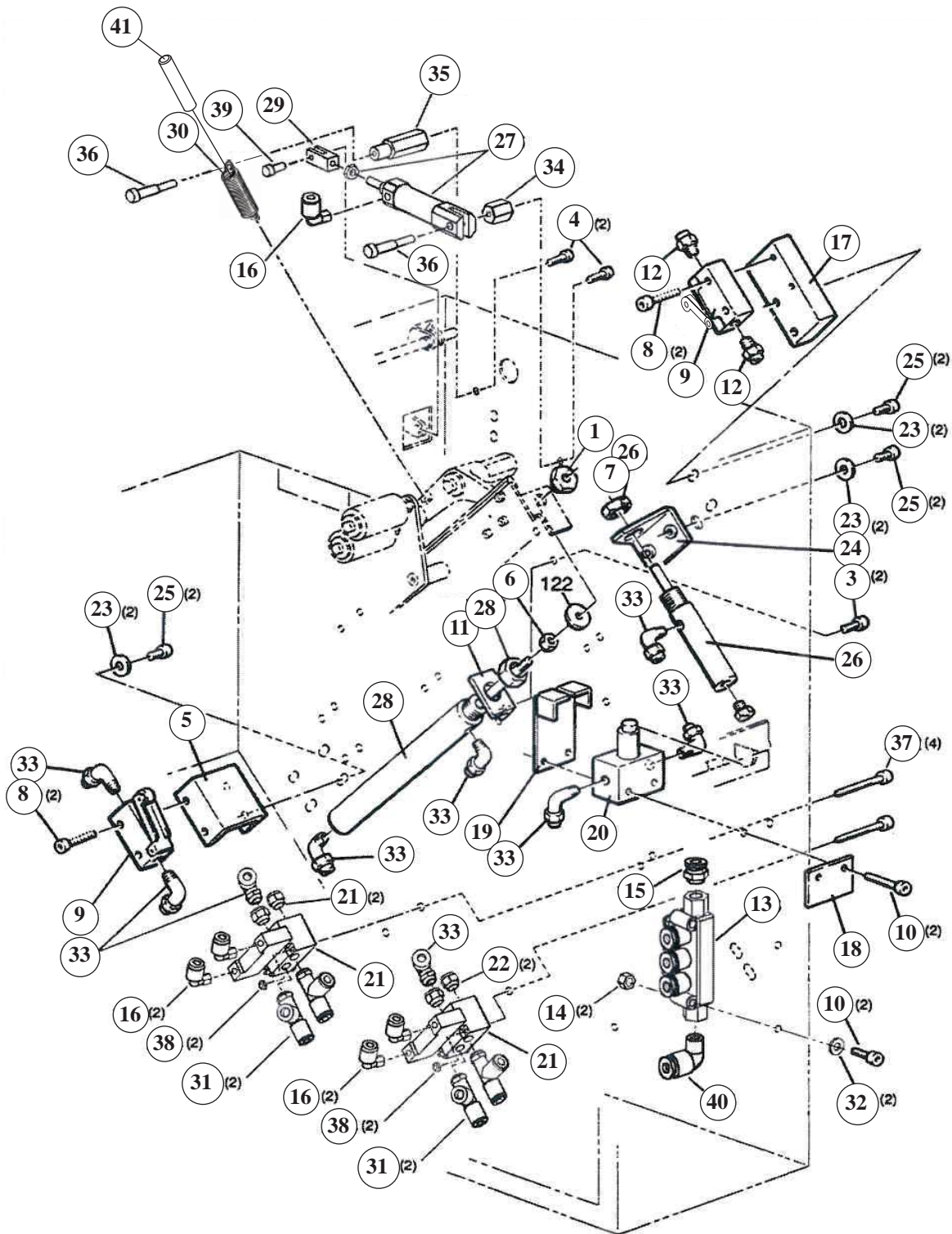

Figure 11-9 Pneumatic Components

Figure 11-9

Ref. No.	3M Part No.	Description
11-9-1	78-8046-8553-1	Mount – Cylinder Rod
11-9-3	70-8656-5938-0	Screw – Soc Hd Hex Soc Dr, 1/4-20 x 1/2 Lg.
11-9-4	26-1006-1770-8	Screw – Soc Hd, Hex Soc Dr, 10-24 x 1/2 Lg
11-9-5	78-8052-6340-3	Mount – Valve, V-6
11-9-6	26-1000-8448-7	Nut – Jam, 1/4-28
11-9-7	26-1002-8745-2	Washer – Plain, Type B, .28 ID x 1.0 OD x .06 Th
11-9-8	70-8000-2155-5	Screw – Soc Hd, Hex Soc Dr, 8-32 x 1 Lg.
11-9-9	26-1004-7410-0	Valve – Air, 3-Way, Roller Actuator, SMC #VM 131 -N01 -01
11-9-10	26-1006-1985-2	Screw – Soc Hd, Hex Soc Dr, 8-32 x 1-1/4 Lg.
11-9-11	78-8052-6338-7	Mount – Cylinder
11-9-12	26-1016-2159-2	Fitting – Male Connector, 1/4 O.D. Tube x 1/8 Male NPT, SMC Corp #KJH07-34S
11-9-13	26-1016-2157-8	Manifold – Air, SMC Corp KM12-07-35-6
11-9-14	26-1006-2447-2	Nut – S-Lock, Nylon Insert, 8-32
11-9-15	26-1016-2158-4	Fitting – Male Connector, 1/4 O.D. Tube x 1/4 Male NPT, SMC Corp #KQ2H07-35S
11-9-16	26-1016-2162-6	Fitting – Male Elbow, 1/4 O.D. Tube x 10-32 Port, SMC Corp #KJY07-32
11-9-17	78-8137-1346-4	Bracket – Valve, V-8
11-9-18	78-8079-5483-5	Spacer – Valve, V-4
11-9-19	78-8046-8509-3	Cover – Switch
11-9-21	26-1016-2156-8	Valve – Air, Operated, 1/4 Port Size, SMC Corp #SYA3240-01T
11-9-22	26-1003-7738-6	Vent – Breather, 1/8 Pipe, Mosier #BV-1
11-9-23	26-1009-3643-9	Washer – Plain, 9/32 ID x 5/8 OD x 1/8 Thk
11-9-24	78-8052-6333-8	Mount – Safety
11-9-25	70-8000-2641-4	Screw – Soc Hd, Hex Soc Dr, 1/4-20 x 5/8 Lg.
11-9-26	26-1016-2148-5	Cylinder – Safety, SMC Corp #NCM75-GCH06-0050
11-9-27	78-8133-9645-0	Cylinder – Paddle (Modified Ref SMC Corp NCJ2D16-050T)
11-9-28	26-1016-2150-1	Cylinder – Feed, SMC Corp #NCMB075-0450C
11-9-29	78-8133-9646-8	Clevis – Rod, Paddle Cylinder
11-9-30	78-8003-9416-1	Spring – Extension; Lee, #LE-037D-5MW ← 12-7995-5344-6
11-9-31	26-1016-2161-8	Fitting - Male Run Tee 1/4 Tube x 1/4 Tube x 1/8 Male NPT, SMC Corp #KJY07-34S
11-9-32	12-7991-1737-4	Washer – Plain, Type A, #8
11-9-33	26-1016-2160-0	Fitting - Elbow, 1/4 Tube x 1/8 NPT SMC Corp KJL07-34S
11-9-34	78-8133-9649-2	Stand-off, Paddle Cylinder Clevis
11-9-35	78-8133-9650-0	Stand-off, Pick-up Arm
11-9-36	26-1016-2154-3	Screw – Shoulder, 1/4 Dia. x 0.75 Lg., 10-24, Alloy Steel
11-9-37	26-1011-8986-3	Screw - Hex Soc. Hd 4-40 x 1.00 Lg.
11-9-38	26-1016-2178-2	Nut - Nylon Insert #4-40
11-9-39	26-1016-2193-1	Screw - Hex Soc. Hd., 10-32 x 1/2 Lg., Stainless Steel
11-9-40	26-1016-2163-4	Fitting - Elbow, 1/4 Tube x 1/4 NPT SMC Corp KQ2L07-35S
11-9-41	78-8137-0065-1	Dowel Rod (spring)

11-9-20 26-1004-7410-0 Valve – Air, 3-Way Actuator Roller, SMC #VM 131-N01-01

THIS PAGE IS BLANK

3M-MaticTM

S867 Type 10500

Single Head Stand

Also used with " 3M-Matic"

S847 "L" Clip Applicator

S857 "L" Clip Applicator

12.1 Purpose of Attachment:

The Part Number 70-0064-0453-0 **S867 Single Head Stand** provides a self-contained system for supporting the "L" Clip Applicator in the bottom taping position for automatically applying "L" clips of Scotch® Filament Tape to box corners. The single head stand allows vertical adjustment of the top work surface and can be adapted to most conveyor or off line systems.

13 - Specifications

13.1 Parts

Single Head Stand consists of:

Quantity	Description
1	Top
2	Table Leg
1	Mounting Bracket
1	Bottom Brace
1	Back Brace
2	Carriage Bolt, 3/8-16 x 2 1/2 Lg.
2	Lock Washer, 3/8
2	Hex Nut, 3/8-16
5	Hex Washer Hd. Screw, 1/4-20 x 3/4 Lg.
5	Fender Washer, 1/4
6	Washer Hd. Hex Nut, 1/4-20
2	Hex Hd. Capscrew, 1/2-13 x 3/4 Lg.
2	Plain Washer, 1/2
2	Channel Washer
2	Square Nut, 1/2-13

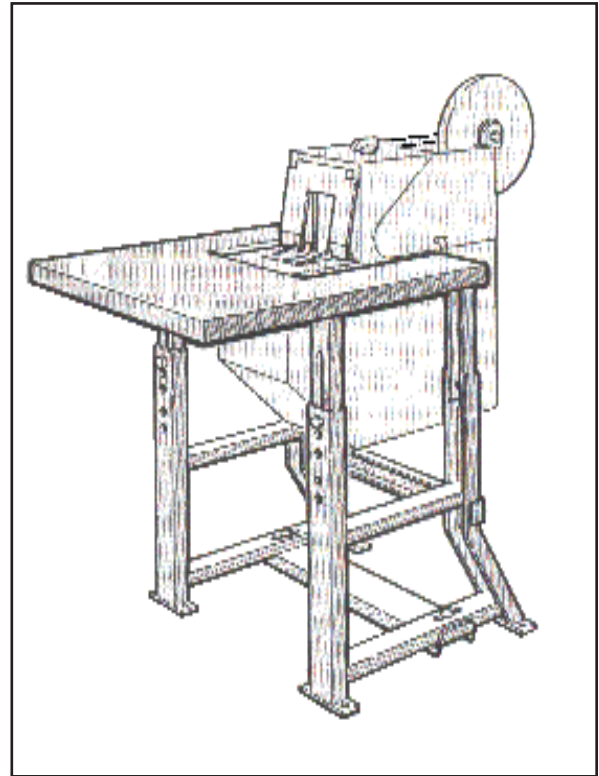

Part Number 70-0064-0453-0 **S867 Single Head Stand, Type 10500** (Shown with S867, Type 10500)

13.2 Overall Dimensions:

Width - 23 3/4 inches [605 mm]
 Length - 43 1/2 inches [1105 mm]
 Height - 45 inches [1145 mm] minimum
 51 1/2 inches [1310 mm] maximum

13.3 Work Surface Height:

Without Casters: 30 inches [762 mm] minimum
 33 inches [839 mm] maximum
 With Casters: 35 inches [889 mm] minimum
 38 inches [965 mm] maximum

13.4 Work Surface size:

Width - 23 3/4 inches [605 mm]
 Length - 25 1/2 inches [650 mm]

13.5 Weight:

Unpackaged 40 lbs. [18.1 kg]
 Packaged 50 lbs. [22.7 kg] est.

14 - Assembly Instructions

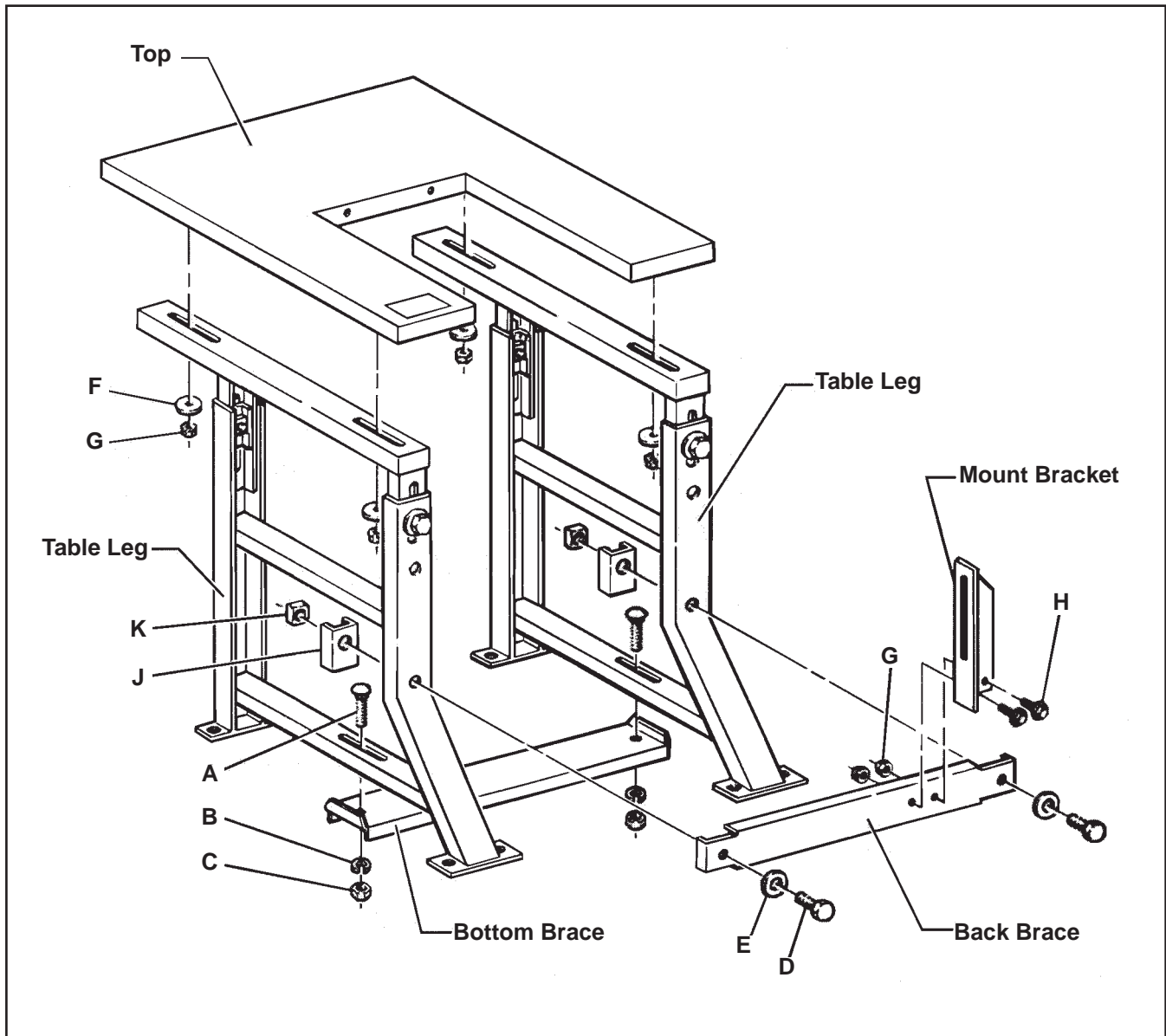

Figure 14-1 Stand Assembly - Right Rear View.

Assembly Instructions

The single head stand is shipped disassembled. A packet containing bolts, washers and nuts is provided for easy stand assembly. Refer to **Figure 14-1** and follow assembly instructions.

1. Assemble as shown **Bottom Brace to Table Legs** using two each 3/8-16 x 2 1/2 lg. carriage bolts (A), 3/8 lock washers (B) and 3/8-16 hex nuts (C).
2. Assemble as shown **Back Brace to Table Legs** using two each 1/2-13 x 3/4 lg. hex hd. capscrews (D), 1/2 plain washer (E), channel washers (J) and 1/2-13 square nuts (K).
3. Assemble as shown **Top to Table Legs** using four each 1/4 fender washers (F) and 1/4-20 washer hex nuts (G). Locate **Top** in full forward position.
4. Assemble as shown **Mount Bracket to Back Brace** using two each 1/4-20 x 3/4 lg. hex washer hd. screws (H) and 1/4-20 washer hex nuts (G).

14 - Assembly Instructions (continued)

14.1 Single Head Stand - Refer to Figure 14-2

Two **Floor Mounting Holes** are provided in each leg base for securing the stand in position if desired. Floor mounting screws are to be supplied by the customer.

14.2 Work Surface Height - Refer to Specifications and Figure 14-2.

Stand work surface height can be adjusted with or without applicator installed. Loosen (do not remove) four leg screws (L) and one mounting bolt (H) to applicator. Position work surface at desired height and tighten all screws and nuts to secure setting.



WARNING

- To reduce the risk associated with muscle strain:
- Use the appropriate rigging and material handling equipment when lifting or repositioning this equipment

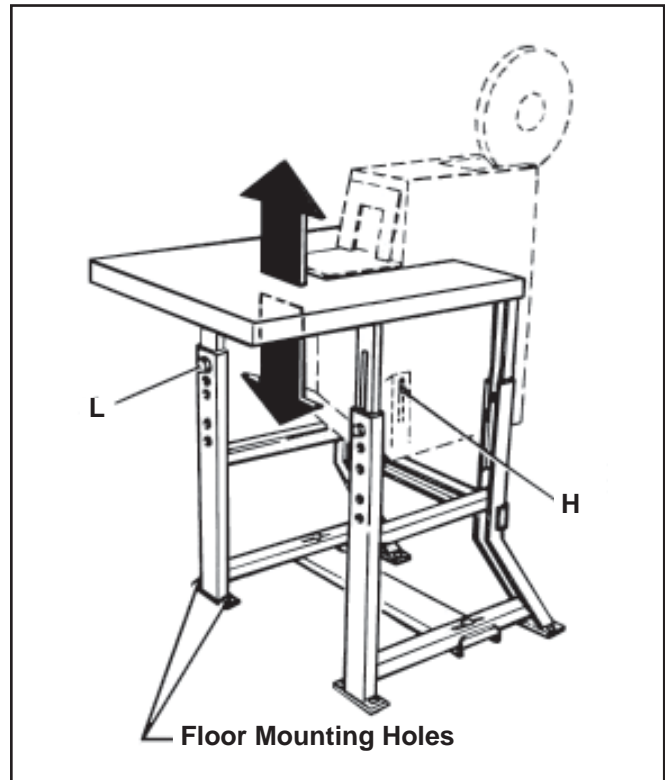

Figure 14-2 Work Surface Adjustment - Right Front View

14.3 Instructions

S-867 Installation - Refer to Figure 14-3

Install applicator to stand as shown using two each 1/4-20 x 3/4 lg. hex hd. washer screws (H) at front of unit. Remove and discard two soc. hd. capscrews. Assemble one each 1/4-20 x 3/4 lg. hex hd. washer screws (H) and 1/4 fender washer (F) at mount bracket on left rear of stand. Position applicator nest surface (M) level with or just below work surface and tighten screws and nuts to secure applicator in position.

Refer to Applicator Instructions and Parts List for complete set-up and operating procedure.

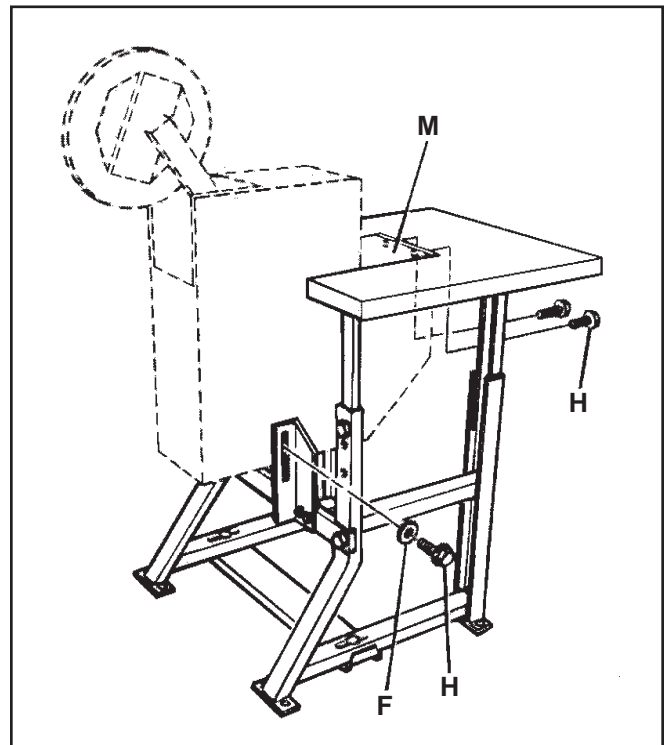

Figure 14-3 Applicator Set-up - Left Rear View

THIS PAGE IS BLANK

14.4 Warranty

Equipment Warranty and Limited Remedy: THE FOLLOWING WARRANTY IS MADE IN LIEU OF ALL OTHER WARRANTIES, EXPRESS OR IMPLIED, INCLUDING, BUT NOT LIMITED TO, THE IMPLIED WARRANTY OF MERCHANTABILITY, THE IMPLIED WARRANTY OF FITNESS FOR A PARTICULAR PURPOSE AND ANY IMPLIED WARRANTY ARISING OUT OF A COURSE OF DEALING, A CUSTOM OR USAGE OF TRADE:

3M warrants that its **3M-Matic™ P/N 70-0064-0453-0 S-867 Single Head Stand, Type 10500** will be free from defects for ninety (90) days after delivery. If any part is proved to be defective within the warranty period, then the exclusive remedy and 3M's and seller's sole obligation shall be, at 3M's option, to repair or replace the part, provided the defective part is returned immediately to 3M's factory or an authorized service station designated by 3M. A part will be presumed to have become defective after the warranty period unless the part is received or 3M is notified of the problem no later than five (5) calendar days after the warranty period. If 3M is unable to repair or replace the part within a reasonable time, then 3M, at its option, will replace the equipment or refund the purchase price. 3M shall have no obligation to provide or pay for the labor required to install the repaired or replacement part. 3M shall have no obligation to repair or replace (1) those parts failing due to operator misuse, carelessness, or due to any accidental cause other than equipment failure, or (2) parts failing due to non-lubrication, inadequate cleaning, improper operating environment, improper utilities or operator error.

Limitation of Liability: 3M and seller shall not be liable for direct, indirect, special, incidental or consequential damages based upon breach of warranty, breach of contract, negligence, strict liability or any other legal theory.

The foregoing Equipment Warranty and Limited Remedy and Limitation of Liability may be changed only by a written agreement signed by authorized officers of 3M and seller.

□

3M Industrial Adhesives and Tapes

3M Center, Building 220-5E-06
St. Paul, MN 55144-1000

"Scotch" and "3M-Matic"
are trademarks of 3M,
St. Paul, Minnesota 55144-1000

Printed in U.S.A.